

| | | |
|--------------------|------------------------------|--------|
| Breclav 08.07.2019 | | Form B |
| Pilot ID | CIVA Intermediate Programme3 | |
| | Flight # | |

FAI AEROBATICS COMMISSION

A

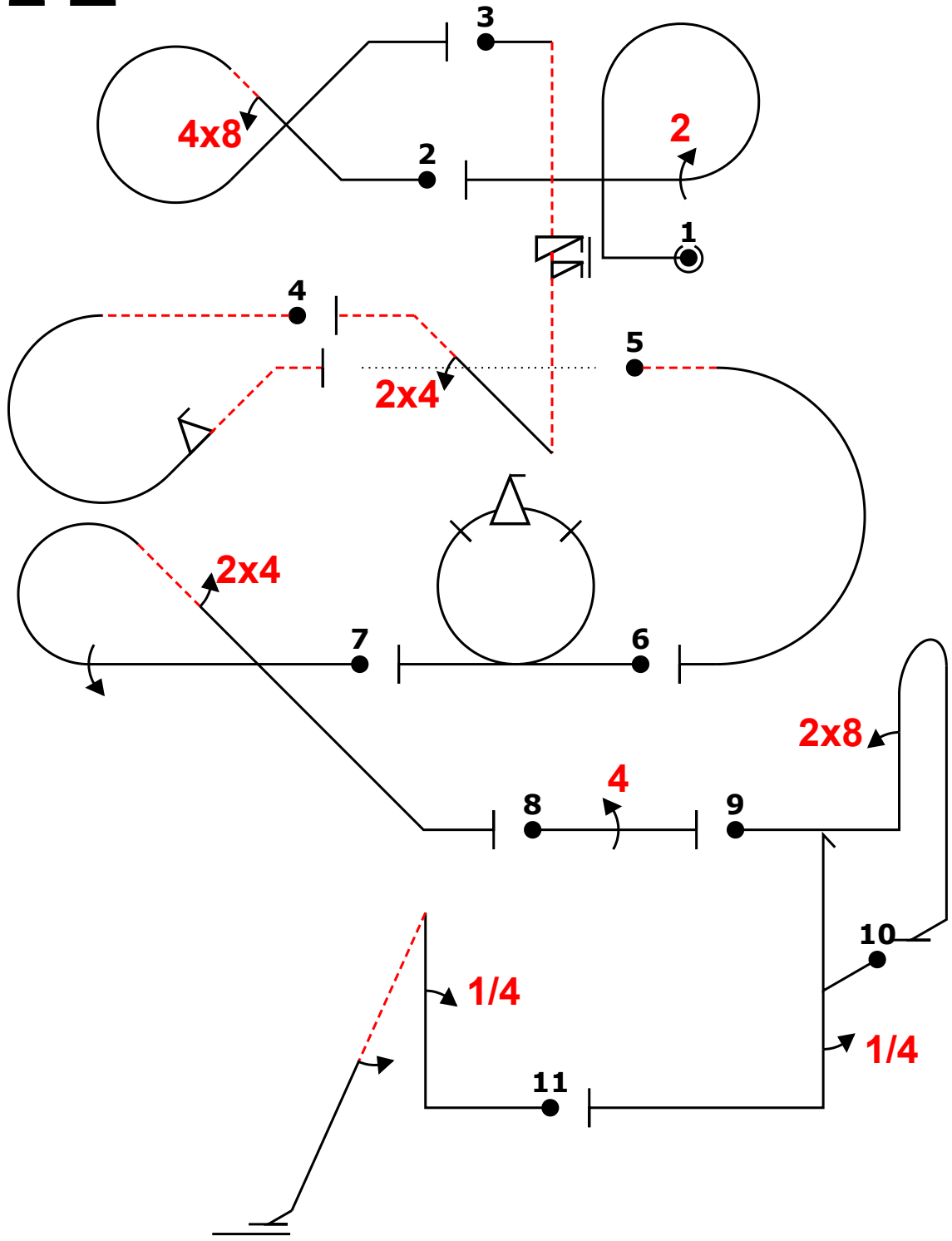
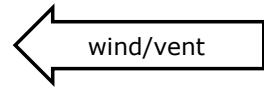

| Power | | | |
|----------------------|----------------------------------|--------------|----|
| Fig | Aresti | K | |
| 1 | 8.6.1.1 J 9.2.3.4 | 11 9 | 20 |
| 2 | 7.3.2.1 G 9.8.2.2 | 14 9 | 23 |
| 3 | 1.2.8.3 A 9.11.1.6 9.4.2.2 | 15 3 7 | 25 |
| 4 | 8.5.6.4 E 9.9.2.2 | 11 13 | 24 |
| 5 | 7.2.1.4 | 6 | 24 |
| Add. | | | |
| 6 | 7.4.1.1 B 9.9.3.4 | 10 11 | 21 |
| 7 | 8.5.6.1 C 9.1.3.4 9.4.4.2 | 10 8 5 | 23 |
| 8 | 1.1.1.1 H 9.4.3.4 | 2 11 | 13 |
| 9 | 8.4.1.1 I 9.8.1.1 | 13 7 | 20 |
| 10 | 5.2.1.1 F 9.1.5.1 | 17 2 | 19 |
| 11 | 1.2.7.1 D 9.1.1.1 9.1.4.2 | 13 6 4 | 23 |
| Total K = 235 | | | |

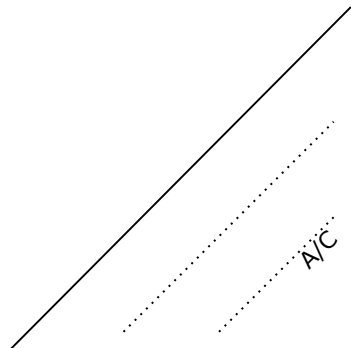

A

wind/vent ←

R

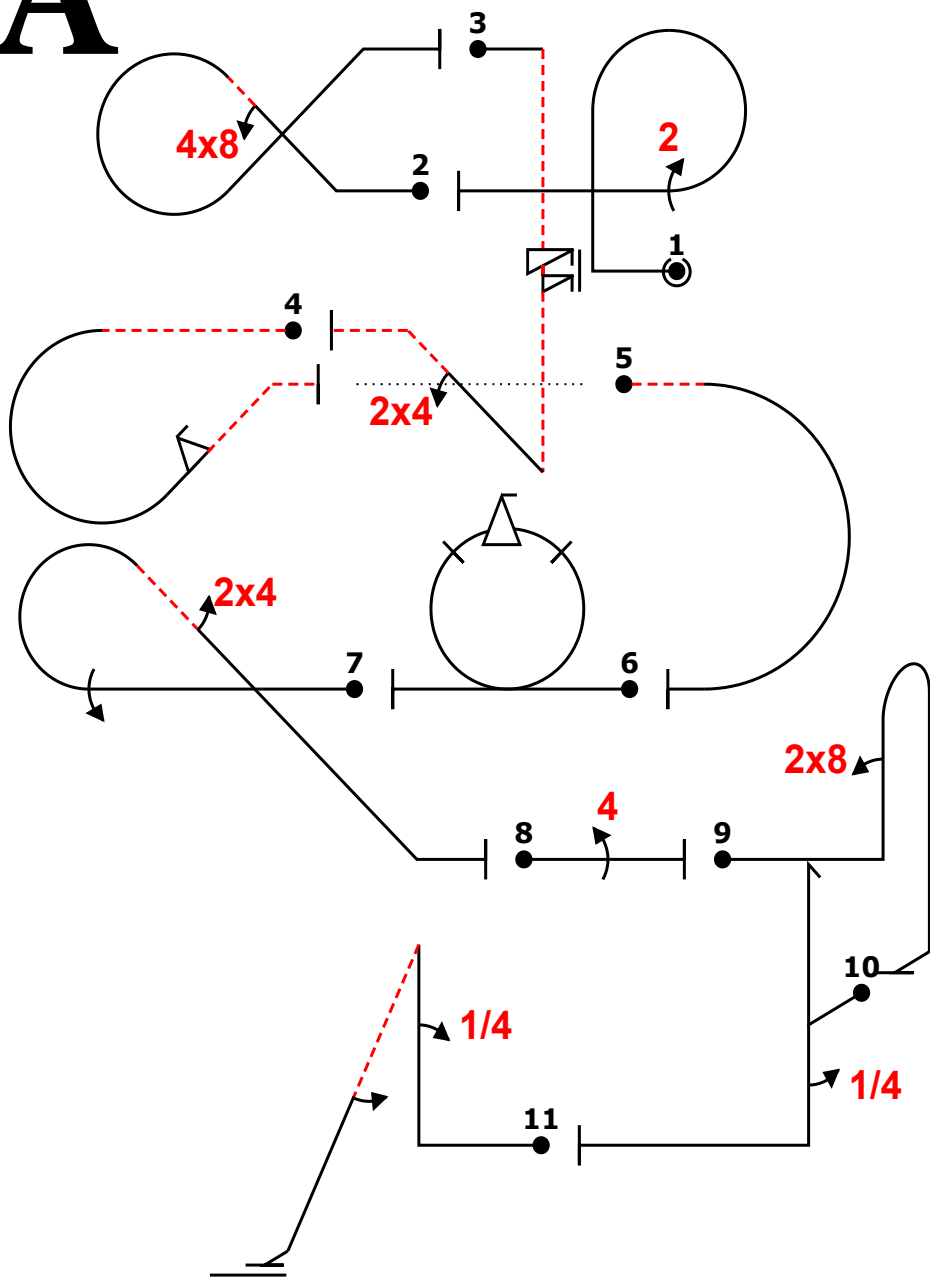

| Fig | Grade | Pos | Remarks |
|-----|-------|-----|---------|
| 1 | . | | |
| 2 | . | | |
| 3 | . | | |
| 4 | . | | |
| 5 | . | | |
| 6 | . | | |
| 7 | . | | |
| 8 | . | | |
| 9 | . | | |
| 10 | . | | |
| 11 | . | | |

Positioning

30

.

| | | | |
|---------------|--|----------------|--|
| Too Low | | Trg Violation | |
| Too High | | Wing Rocks | |
| Interruptions | | Disqual Fig | |
| Insertions | | Other(note...) | |

ed "@j" rp,22+~ "@G" 48g "@A" '+.6s.'ik'24'''''' - "@E" 2% -''''''ic'2f'''''''' (12,0) 9% "@L" -''a+'''' "@ B" of "@C" -1% '1c''24... "@H" 44 "@I" ~8b'',.'''+'''' "@F" h'4'+~'' "@D" ~,4k2+''

| Fig 1 J | K | Fig 2 G | K | Fig 3 A | K | Fig 4 E | K | Fig 5 L | K | Fig 6 B | K | Fig 7 C | K | Fig 8 H | K | Fig 9 I | K | Fig 10 F | K | Fig 11 D | K |
|---------|----|---------|----|---------|----|---------|----|---------|----|---------|----|---------|----|---------|----|---------|----|----------|----|----------|----|
| 8.6.1.1 | 11 | 7.3.2.1 | 14 | 1.2.8.3 | 15 | 8.5.6.4 | 11 | 7.2.1.4 | 6 | 7.4.1.1 | 10 | 8.5.6.1 | 10 | 1.1.1.1 | 2 | 8.4.1.1 | 13 | 5.2.1.1 | 17 | 1.2.7.1 | 13 |
| 9.2.3.4 | 9 | 9.8.2.2 | 9 | 9.1.1.6 | 3 | 9.9.2.2 | 13 | | | 9.9.3.4 | 11 | 9.1.3.4 | 8 | 9.4.3.4 | 11 | 9.8.1.1 | 7 | 9.1.5.1 | 2 | 9.1.1.1 | 6 |
| | | | | 9.4.2.2 | 7 | | | | | | | 9.4.4.2 | 5 | | | | | | | 9.1.4.2 | 4 |
| | 20 | | 23 | | 25 | | 24 | | 24 | | 21 | | 23 | | 13 | | 20 | | 19 | | 23 |

| | | |
|-------------|--------|----------|
| Judges Name | | Flight # |
| Signature | Number | |

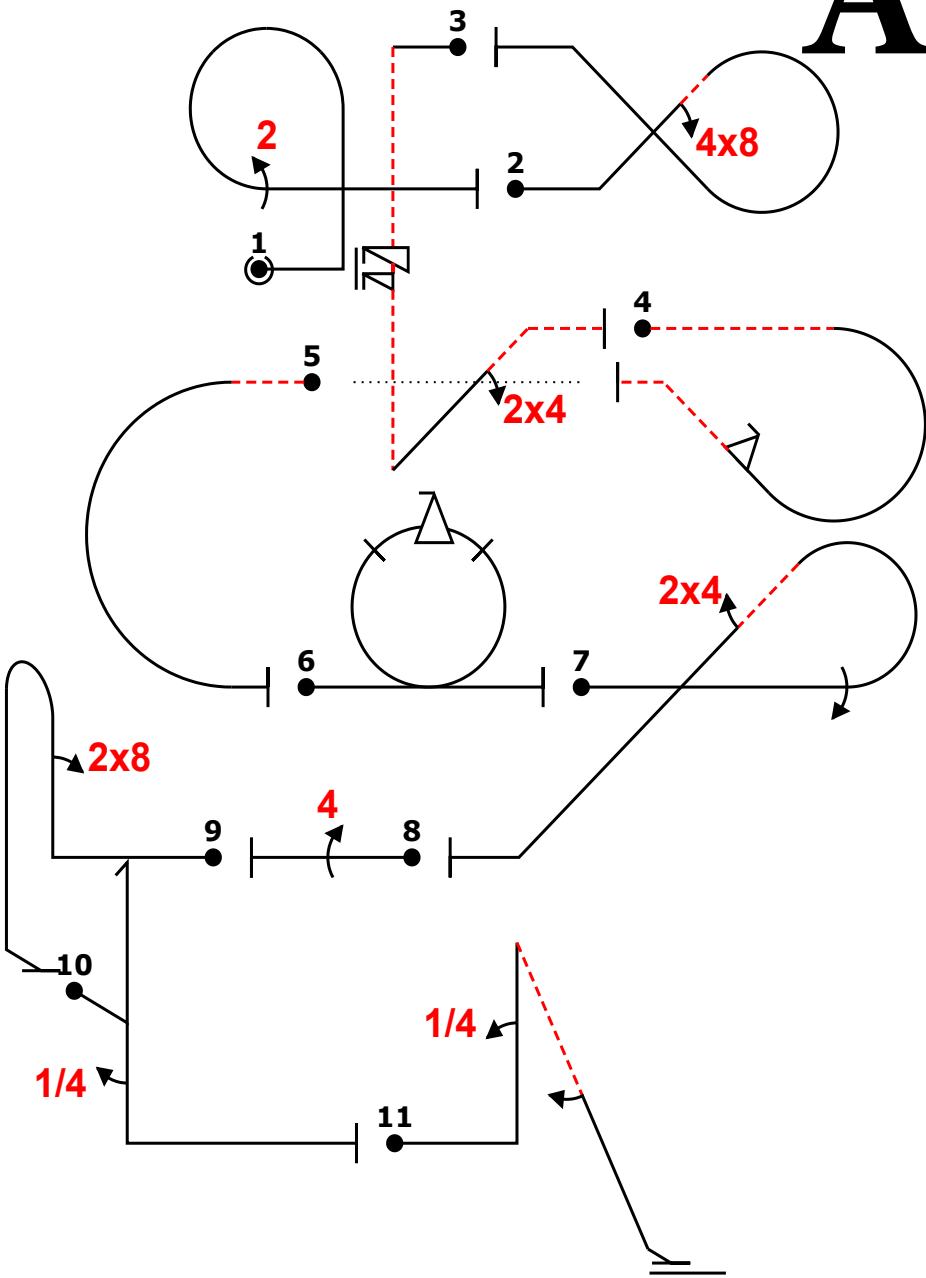

| Fig | Grade | Pos | Remarks |
|-----|-------|-----|---------|
| 1 | . | | |
| 2 | . | | |
| 3 | . | | |
| 4 | . | | |
| 5 | . | | |
| 6 | . | | |
| 7 | . | | |
| 8 | . | | |
| 9 | . | | |
| 10 | . | | |
| 11 | . | | |

Positioning **30**

| | | | |
|---------------|--|----------------|--|
| Too Low | | Trg Violation | |
| Too High | | Wing Rocks | |
| Interruptions | | Disqual Fig | |
| Insertions | | Other(note...) | |

ed "@j" rp,22+~ "@G" 48g "@A" '+.6s.'ik'24'''''' - "@E" 2% -''''''ic'2F'''''' (12,0) 9% "@L" -''a+'' "@ B" of "@C" -1% '1c''24... "@H" 44 "@I" ~'8b'',, ''+'' "@F" h'4'+~ "@D" ~,,4k2+''

| | | | | | | | | | | | | | | | | | | | | | |
|----------------|-----------|----------------|-----------|----------------|-----------|----------------|-----------|----------------|-----------|----------------|-----------|----------------|-----------|----------------|-----------|----------------|-----------|-----------------|-----------|-----------------|-----------|
| Fig 1 J | K | Fig 2 G | K | Fig 3 A | K | Fig 4 E | K | Fig 5 L | K | Fig 6 B | K | Fig 7 C | K | Fig 8 H | K | Fig 9 I | K | Fig 10 F | K | Fig 11 D | K |
| 8.6.1.1 | 11 | 7.3.2.1 | 14 | 1.2.8.3 | 15 | 8.5.6.4 | 11 | 7.2.1.4 | 6 | 7.4.1.1 | 10 | 8.5.6.1 | 10 | 1.1.1.1 | 2 | 8.4.1.1 | 13 | 5.2.1.1 | 17 | 1.2.7.1 | 13 |
| 9.2.3.4 | 9 | 9.8.2.2 | 9 | 9.11.1.6 | 3 | 9.9.2.2 | 13 | | | 9.9.3.4 | 11 | 9.1.3.4 | 8 | 9.4.3.4 | 11 | 9.8.1.1 | 7 | 9.1.5.1 | 2 | 9.1.1.1 | 6 |
| | | | | 9.4.2.2 | 7 | | | | | | | 9.4.4.2 | 5 | | | | | | | 9.1.4.2 | 4 |
| | 20 | | 23 | | 25 | | 24 | | 24 | | 21 | | 23 | | 13 | | 20 | | 19 | | 23 |



| | | | |
|--------------------|------------------------------|----------|----------|
| Breclav 08.07.2019 | | B | Form B |
| Pilot ID | CIVA Intermediate Programme3 | | Flight # |

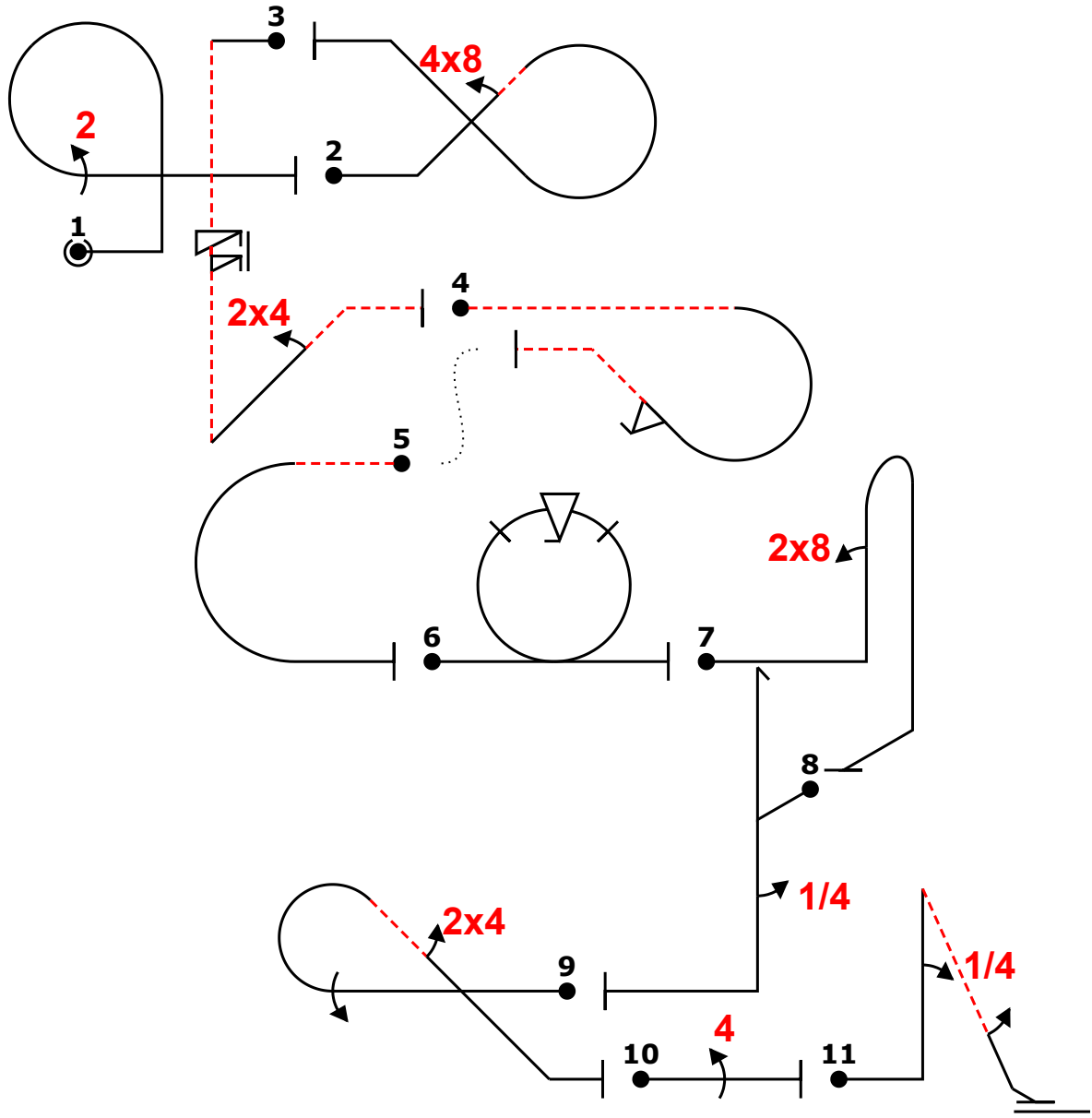
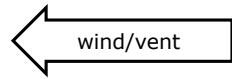

| Power | | | |
|----------------------|------------|----|----|
| Fig | Aresti | K | |
| 1 | 8.6.1.1 | 11 | 20 |
| | J 9.2.3.4 | 9 | |
| 2 | 7.3.2.1 | 14 | 23 |
| | G 9.8.2.2 | 9 | |
| 3 | 1.2.8.3 | 15 | 25 |
| | A 9.11.1.6 | 3 | |
| | 9.4.2.2 | 7 | |
| 4 | 8.5.6.4 | 11 | 24 |
| | E 9.9.2.2 | 13 | |
| 5 | 7.2.1.4 | 6 | 24 |
| 6 | B 7.4.1.1 | 10 | 21 |
| | 9.9.3.4 | 11 | |
| 7 | I 8.4.1.1 | 13 | 20 |
| | 9.8.1.1 | 7 | |
| 8 | F 5.2.1.1 | 17 | 19 |
| | 9.1.5.1 | 2 | |
| 9 | C 8.5.6.1 | 10 | 23 |
| | 9.1.3.4 | 8 | |
| | 9.4.4.2 | 5 | |
| 10 | H 1.1.1.1 | 2 | 13 |
| | 9.4.3.4 | 11 | |
| 11 | D 1.2.7.1 | 13 | 23 |
| | 9.1.1.1 | 6 | |
| | 9.1.4.2 | 4 | |
| Total K = 235 | | | |



Figure K

235

Total K

265

Judges Name

Flight #

Signature

Number

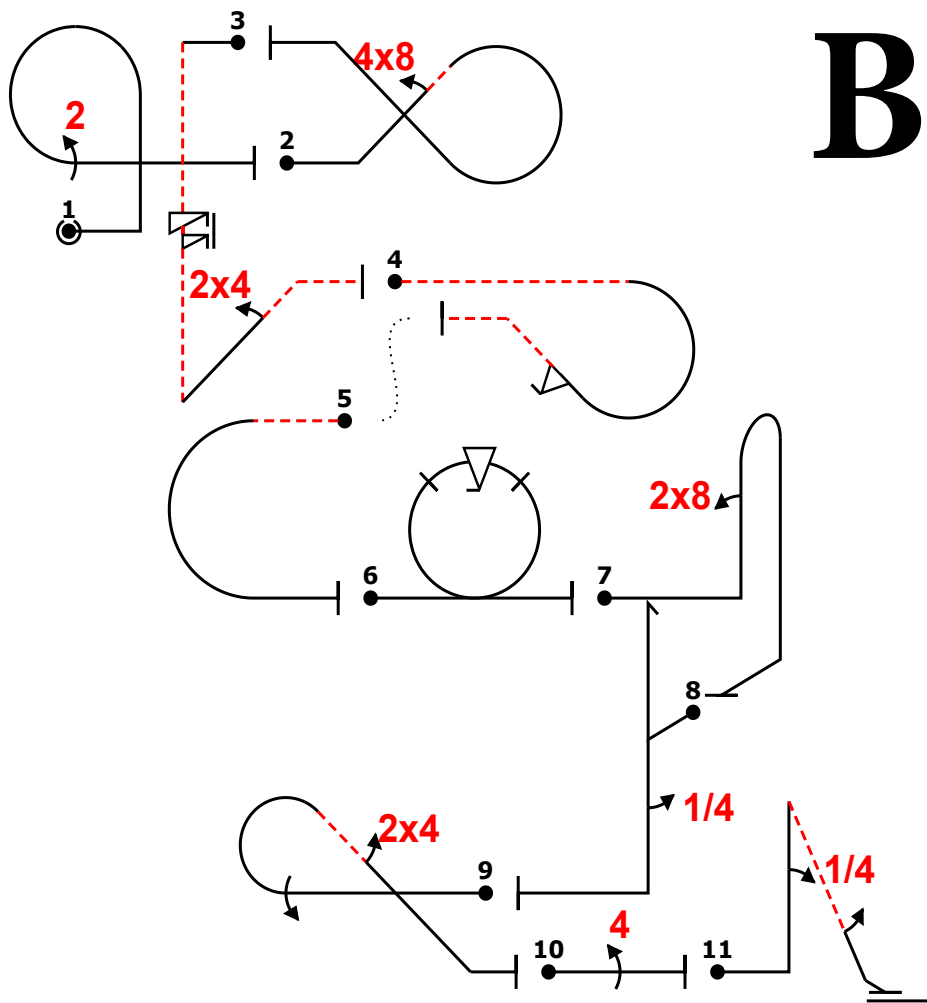

B

| Fig | Grade | Pos | Remarks |
|-----|-------|-----|---------|
| 1 | . | | |
| 2 | . | | |
| 3 | . | | |
| 4 | . | | |
| 5 | . | | |
| 6 | . | | |
| 7 | . | | |
| 8 | . | | |
| 9 | . | | |
| 10 | . | | |
| 11 | . | | |

Positioning

30

.

| | | | |
|---------------|--|----------------|--|
| Too Low | | Trg Violation | |
| Too High | | Wing Rocks | |
| Interruptions | | Disqual Fig | |
| Insertions | | Other(note...) | |

"@J" rp22+~ "@G" ``48g "@A" `+. '6s.' 'ik' 24'''''' - "@E" -ic' 2f'''''' - (-2,6) 3% "@L" -a "@B" of "@I" ~8b'',. '' "@F" h4.+~ -3% "@C" .1c.24.' "@H" 44 "@D" /,4k2''''''+''

| Fig 1 J | K | Fig 2 G | K | Fig 3 A | K | Fig 4 E | K | Fig 5 L | K | Fig 6 B | K | Fig 7 I | K | Fig 8 F | K | Fig 9 C | K | Fig 10 H | K | Fig 11 D | K |
|---------|----|---------|----|----------|----|---------|----|---------|----|---------|----|---------|----|---------|----|---------|----|----------|----|----------|----|
| 8.6.1.1 | 11 | 7.3.2.1 | 14 | 1.2.8.3 | 15 | 8.5.6.4 | 11 | 7.2.1.4 | 6 | 7.4.1.1 | 10 | 8.4.1.1 | 13 | 5.2.1.1 | 17 | 8.5.6.1 | 10 | 1.1.1.1 | 2 | 1.2.7.1 | 13 |
| 9.2.3.4 | 9 | 9.8.2.2 | 9 | 9.11.1.6 | 3 | 9.9.2.2 | 13 | | | 9.9.3.4 | 11 | 9.8.1.1 | 7 | 9.1.5.1 | 2 | 9.1.3.4 | 8 | 9.4.3.4 | 11 | 9.1.1.1 | 6 |
| | 20 | | 23 | 9.4.2.2 | 7 | | 24 | | 24 | | 21 | | 20 | | 19 | 9.4.4.2 | 5 | | 13 | 9.1.4.2 | 4 |
| | | | | | | | | | | | | | | | | | 23 | | 13 | | 23 |

L wind/vent →

B

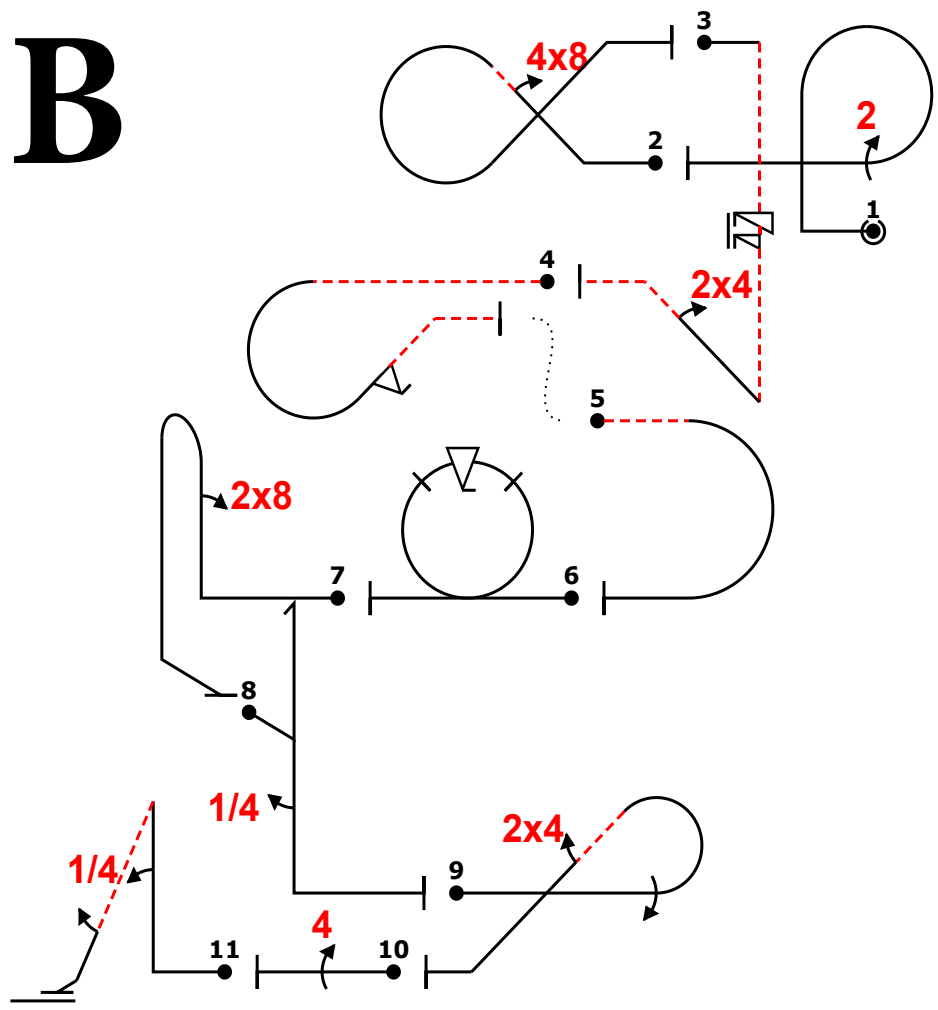

| Fig | Grade | Pos | Remarks |
|-----|-------|-----|---------|
| 1 | . | | |
| 2 | . | | |
| 3 | . | | |
| 4 | . | | |
| 5 | . | | |
| 6 | . | | |
| 7 | . | | |
| 8 | . | | |
| 9 | . | | |
| 10 | . | | |
| 11 | . | | |

Positioning **30**

| | | | |
|---------------|--|----------------|--|
| Too Low | | Trg Violation | |
| Too High | | Wing Rocks | |
| Interruptions | | Disqual Fig | |
| Insertions | | Other(note...) | |

"@J" np22+~ "@G" ``48g "@A" `+. '6s.' 'ik' 24'''''' - "@E" -ic' 2f'''''' - (-2,6) 3% "@L" -a "@B" of "@I" ~8b'',. '' "@F" h4.+~ -3% "@C" .1c.24.' "@H" 44 "@D" /,4k2''''''+''

| Fig 1 J | K | Fig 2 G | K | Fig 3 A | K | Fig 4 E | K | Fig 5 L | K | Fig 6 B | K | Fig 7 I | K | Fig 8 F | K | Fig 9 C | K | Fig 10 H | K | Fig 11 D | K |
|---------|-----------|---------|-----------|----------|-----------|---------|-----------|---------|-----------|---------|-----------|---------|-----------|---------|-----------|---------|-----------|----------|-----------|----------|-----------|
| 8.6.1.1 | 11 | 7.3.2.1 | 14 | 1.2.8.3 | 15 | 8.5.6.4 | 11 | 7.2.1.4 | 6 | 7.4.1.1 | 10 | 8.4.1.1 | 13 | 5.2.1.1 | 17 | 8.5.6.1 | 10 | 1.1.1.1 | 2 | 1.2.7.1 | 13 |
| 9.2.3.4 | 9 | 9.8.2.2 | 9 | 9.11.1.6 | 3 | 9.9.2.2 | 13 | | | 9.9.3.4 | 11 | 9.8.1.1 | 7 | 9.1.5.1 | 2 | 9.1.3.4 | 8 | 9.4.3.4 | 11 | 9.1.1.1 | 6 |
| | | | | 9.4.2.2 | 7 | | | | | | | | | | | 9.4.4.2 | 5 | | | 9.1.4.2 | 4 |
| | 20 | | 23 | | 25 | | 24 | | 24 | | 21 | | 20 | | 19 | | 23 | | 13 | | 23 |



FAI

AEROBATICS COMMISSION

Breclav 08.07.2019

C

Form B

Pilot ID

CIVA Intermediate Programme3

Flight #

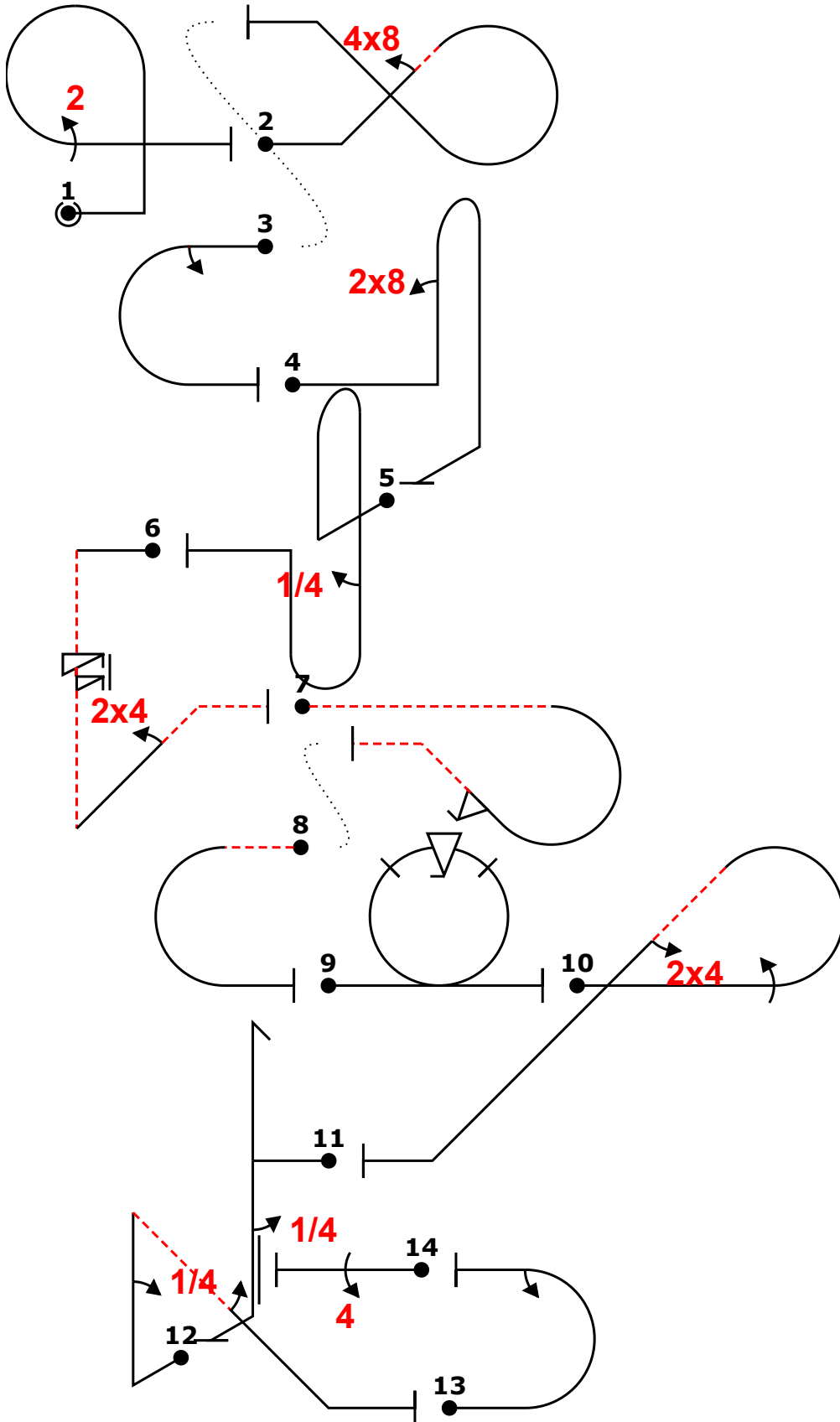
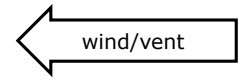

| Power | | | |
|----------------------|----------|----|----|
| Fig | Aresti | K | |
| 1 | 8.6.1.1 | 11 | 20 |
| J | 9.2.3.4 | 9 | |
| 2 | 7.3.2.1 | 14 | 23 |
| G | 9.8.2.2 | 9 | |
| 3 | 7.2.3.3 | 6 | 6 |
| Add. | 9.1.3.2 | 4 | |
| 4 | 8.4.1.1 | 13 | 20 |
| I | 9.8.1.1 | 7 | |
| 5 | 8.8.2.1 | 19 | 6 |
| Add. | 9.1.5.1 | 2 | |
| 6 | 1.2.8.3 | 15 | 25 |
| A | 9.11.1.6 | 3 | |
| | 9.4.2.2 | 7 | |
| 7 | 8.5.6.4 | 11 | 24 |
| E | 9.9.2.2 | 13 | |
| 8 | 7.2.1.4 | 6 | 6 |
| Add. | | | |
| 9 | 7.4.1.1 | 10 | 21 |
| B | 9.9.3.4 | 11 | |
| 10 | 8.5.6.1 | 10 | 23 |
| C | 9.1.3.4 | 8 | |
| | 9.4.4.2 | 5 | |
| 11 | 5.2.1.1 | 17 | 19 |
| F | 9.1.5.1 | 2 | |
| 12 | 1.2.7.1 | 13 | 23 |
| D | 9.1.1.1 | 6 | |
| | 9.1.4.2 | 4 | |
| 13 | 7.2.2.1 | 6 | 6 |
| Add. | 9.1.3.2 | 4 | |
| 14 | 1.1.1.1 | 2 | 13 |
| H | 9.4.3.4 | 11 | |
| Total K = 235 | | | |



Figure K
235
Total K
265

| | | |
|-------------|--------|----------|
| Judges Name | | Flight # |
| Signature | Number | |

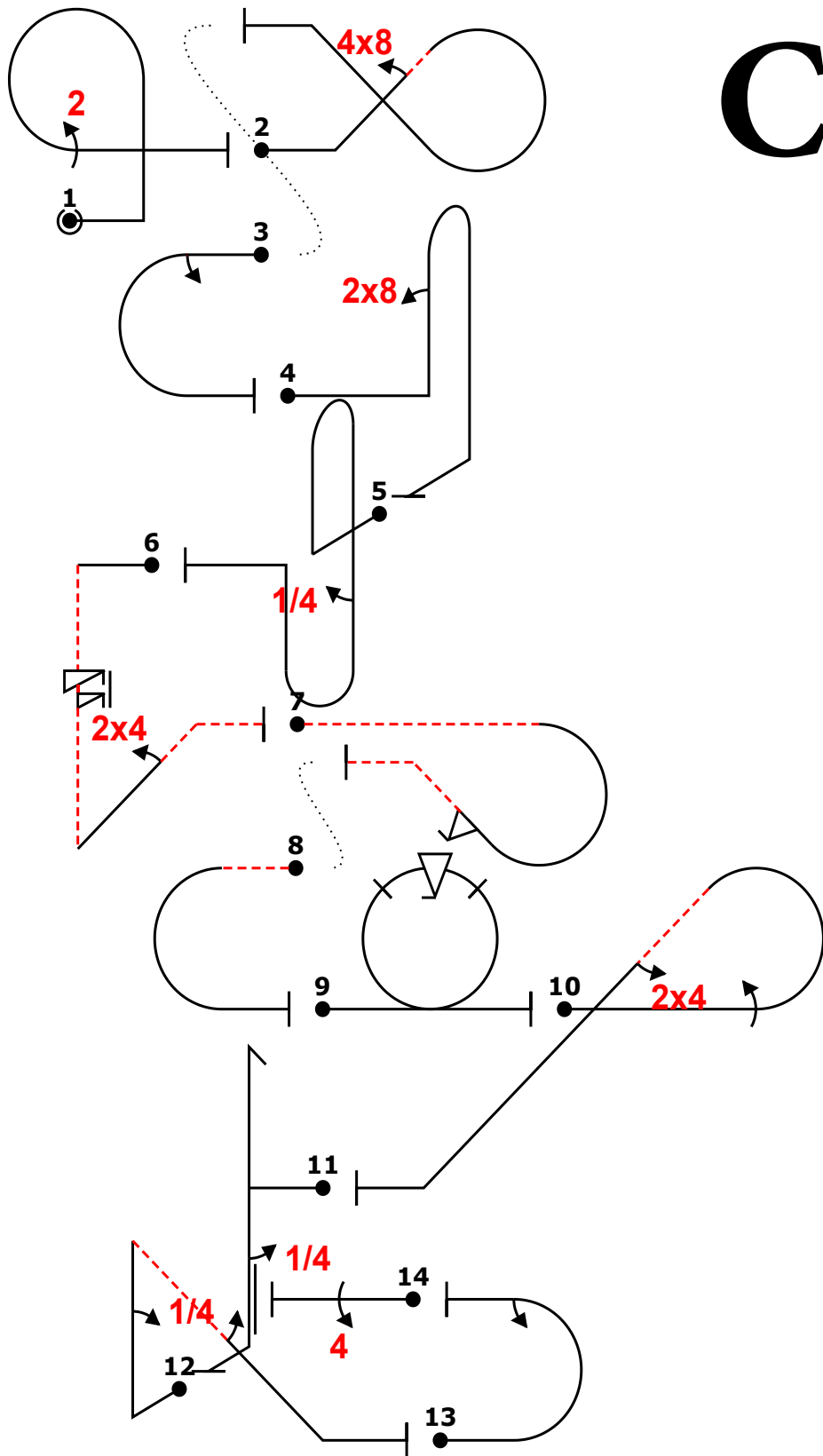

| Fig | Grade | Pos | Remarks |
|-----|-------|-----|---------|
| 1 | . | | |
| 2 | . | | |
| 3 | . | | |
| 4 | . | | |
| 5 | . | | |
| 6 | . | | |
| 7 | . | | |
| 8 | . | | |
| 9 | . | | |
| 10 | . | | |
| 11 | . | | |
| 12 | . | | |
| 13 | . | | |
| 14 | . | | |

Positioning
30

| | | | |
|---------------|--|----------------|--|
| Too Low | | Trg Violation | |
| Too High | | Wing Rocks | |
| Interruptions | | Disqual Fig | |
| Insertions | | Other(note...) | |

"@J" rp22+ "@G" 48g (5,13) "@L" 2a "@I" ~8b`',... "@L" bb(,4) "@A" 6s.'ik'24'''''' - "@E" -ic'2f'''''' - (1,6) "@L" -a "@B" of "@C" 1c.24... "@F" h4. "@D" ,4k2~ "@L" m2 "@H" 44

| Fig 1 J | K | Fig 2 G | K | Fig 3 L | K | Fig 4 I | K | Fig 5 L | K | Fig 6 A | K | Fig 7 E | K | Fig 8 L | K | Fig 9 B | K | Fig 10 C | K | Fig 11 F | K | Fig 12 D | K | Fig 13 L | K | Fig 14 H | K |
|---------|----|---------|----|---------|---|---------|----|---------|----|----------|----|---------|----|---------|---|---------|----|----------|----|----------|----|----------|----|----------|---|----------|----|
| 8.6.1.1 | 11 | 7.3.2.1 | 14 | 7.2.3.3 | 6 | 8.4.1.1 | 13 | 8.8.2.1 | 19 | 1.2.8.3 | 15 | 8.5.6.4 | 11 | 7.2.1.4 | 6 | 7.4.1.1 | 10 | 8.5.6.1 | 10 | 5.2.1.1 | 17 | 1.2.7.1 | 13 | 7.2.2.1 | 6 | 1.1.1.1 | 2 |
| 9.2.3.4 | 9 | 9.8.2.2 | 9 | 9.1.3.2 | 4 | 9.8.1.1 | 7 | 9.1.5.1 | 2 | 9.11.1.6 | 3 | 9.9.2.2 | 13 | | | 9.9.3.4 | 11 | 9.1.3.4 | 8 | 9.1.5.1 | 2 | 9.1.1.1 | 6 | 9.1.3.2 | 4 | 9.4.3.4 | 11 |
| | 20 | | 23 | | 6 | | 20 | | 6 | | 25 | | 24 | | 6 | | 21 | | 23 | | 19 | | 23 | | 6 | | 13 |

| | | |
|-------------|--------|----------|
| Judges Name | | Flight # |
| Signature | Number | |



C

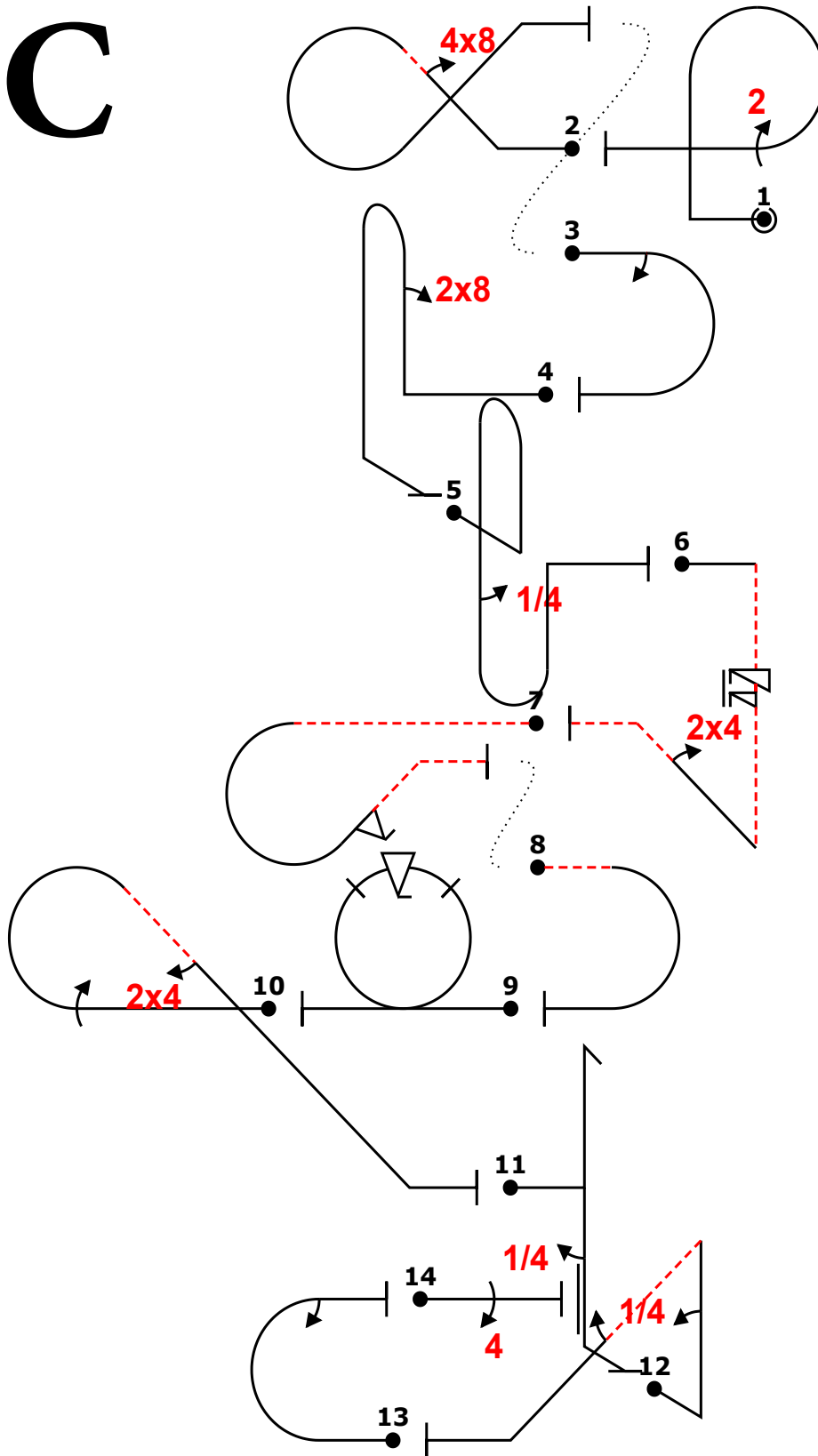

| Fig | Grade | Pos | Remarks |
|-----|-------|-----|---------|
| 1 | . | | |
| 2 | . | | |
| 3 | . | | |
| 4 | . | | |
| 5 | . | | |
| 6 | . | | |
| 7 | . | | |
| 8 | . | | |
| 9 | . | | |
| 10 | . | | |
| 11 | . | | |
| 12 | . | | |
| 13 | . | | |
| 14 | . | | |

| | | |
|-------------|----|---|
| Positioning | 30 | . |
|-------------|----|---|

| | | | |
|---------------|--|----------------|--|
| Too Low | | Trg Violation | |
| Too High | | Wing Rocks | |
| Interruptions | | Disqual Fig | |
| Insertions | | Other(note...) | |

"@J" rp22+ "@G" ``48g (5,13) "@L" 2a "@I" ~8b``,` " " "@L" bb(,4) "@A" 6s."ik`24`" " " "@E" -ic`2f`" (1,6) "@L" -a "@B" of "@C" ``1c.24... "@F" h4. "@D" ,4k2~ "@L" m2 "@H" 44

| Fig 1 J | K | Fig 2 G | K | Fig 3 L | K | Fig 4 I | K | Fig 5 L | K | Fig 6 A | K | Fig 7 E | K | Fig 8 L | K | Fig 9 B | K | Fig 10 C | K | Fig 11 F | K | Fig 12 D | K | Fig 13 L | K | Fig 14 H | K |
|---------|----|---------|----|---------|---|---------|----|---------|----|----------|----|---------|----|---------|---|---------|----|----------|----|----------|----|----------|----|----------|---|----------|----|
| 8.6.1.1 | 11 | 7.3.2.1 | 14 | 7.2.3.3 | 6 | 8.4.1.1 | 13 | 8.8.2.1 | 19 | 1.2.8.3 | 15 | 8.5.6.4 | 11 | 7.2.1.4 | 6 | 7.4.1.1 | 10 | 8.5.6.1 | 10 | 5.2.1.1 | 17 | 1.2.7.1 | 13 | 7.2.2.1 | 6 | 1.1.1.1 | 2 |
| 9.2.3.4 | 9 | 9.8.2.2 | 9 | 9.1.3.2 | 4 | 9.8.1.1 | 7 | 9.1.5.1 | 2 | 9.11.1.6 | 3 | 9.9.2.2 | 13 | | | 9.9.3.4 | 11 | 9.1.3.4 | 8 | 9.1.5.1 | 2 | 9.1.1.1 | 6 | 9.1.3.2 | 4 | 9.4.3.4 | 11 |
| | 20 | | 23 | | 6 | | 20 | | 6 | | 25 | | 24 | | 6 | | 21 | | 23 | | 19 | | 23 | | 6 | | 13 |

D

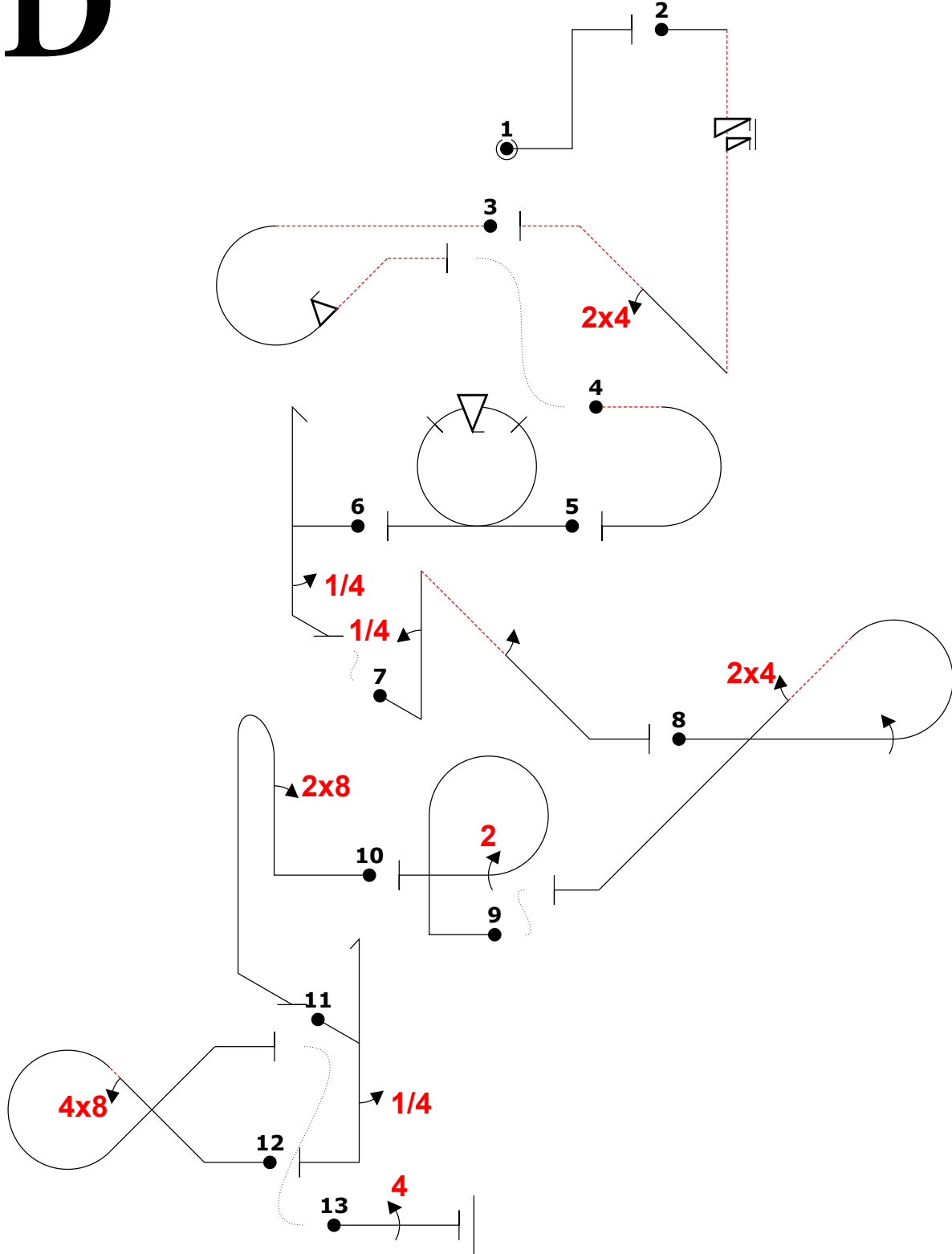
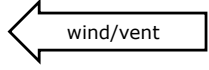

| Power | | | |
|-------------|----------|----|----|
| Fig | Aresti | K | |
| 1 | 1.1.6.1 | 10 | 8 |
| Add. | | | |
| 2 | 1.2.8.3 | 15 | 25 |
| A | 9.11.1.6 | 3 | |
| | 9.4.2.2 | 7 | |
| 3 | 8.5.6.4 | 11 | 24 |
| E | 9.9.2.2 | 13 | |
| Add. | | 6 | 8 |
| 5 | 7.4.1.1 | 10 | 21 |
| B | 9.9.3.4 | 11 | |
| 6 | 5.2.1.1 | 17 | 19 |
| F | 9.1.5.1 | 2 | |
| 7 | 1.2.7.1 | 13 | 23 |
| D | 9.1.1.1 | 6 | |
| | 9.1.4.2 | 4 | |
| 8 | 8.5.6.1 | 10 | 23 |
| C | 9.1.3.4 | 8 | |
| | 9.4.4.2 | 5 | |
| 9 | 8.6.1.1 | 11 | 20 |
| J | 9.2.3.4 | 9 | |
| 10 | 8.4.1.1 | 13 | 20 |
| I | 9.8.1.1 | 7 | |
| Add. | | 17 | 8 |
| 11 | 5.2.1.1 | 17 | 23 |
| G | 9.8.2.2 | 9 | |
| 12 | 7.3.2.1 | 14 | 13 |
| H | 9.4.3.4 | 11 | |

Total K = 235

Pilot _____
 A/C _____

D

wind/vent ← **R**

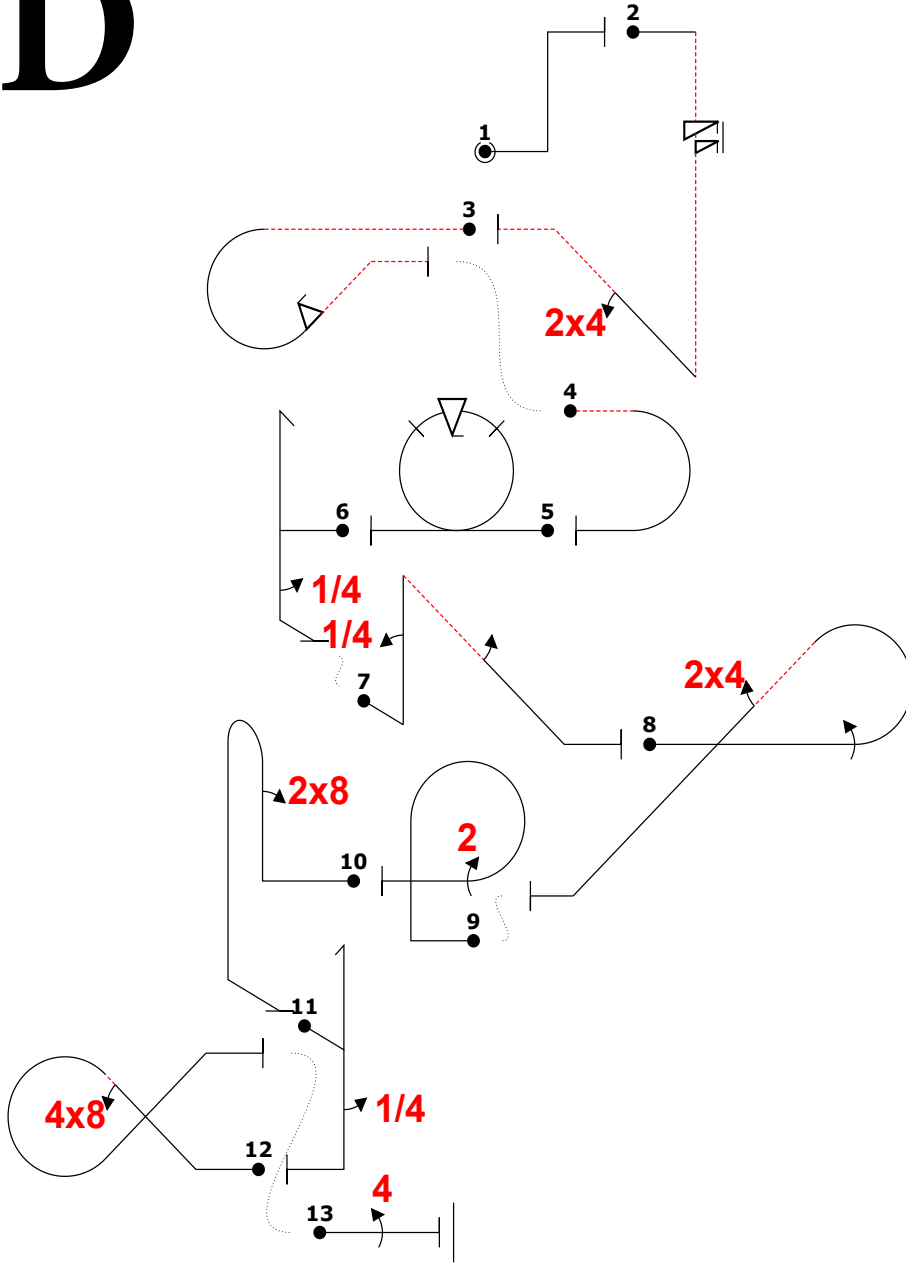

| Fig | Grade | Pos | Remarks |
|-----|-------|-----|---------|
| 1 | . | | |
| 2 | . | | |
| 3 | . | | |
| 4 | . | | |
| 5 | . | | |
| 6 | . | | |
| 7 | . | | |
| 8 | . | | |
| 9 | . | | |
| 10 | . | | |
| 11 | . | | |
| 12 | . | | |
| 13 | . | | |

Positioning
30 .

| | | | |
|---------------|--|----------------|--|
| Too Low | | Trg Violation | |
| Too High | | Wing Rocks | |
| Interruptions | | Disqual Fig | |
| Insertions | | Other(note...) | |

"@L" v "@A" 6s...''ik24'' - "@E" -ic''2f'' - (6,10) "@L" -a "@B" o,f "@F" /h4 (0,2) "@D" 4k2 "@C" 1c.,24...+ (0,3) "@J" rp,22 "@I" ,8b.. "@L" ``h4''> "@G" 48''g (0,12) "@H" 44

| Fig 1 L | K | Fig 2 A | K | Fig 3 E | K | Fig 4 L | K | Fig 5 B | K | Fig 6 F | K | Fig 7 D | K | Fig 8 C | K | Fig 9 J | K | Fig 10 I | K | Fig 11 L | K | Fig 12 G | K | Fig 13 H | K |
|---------|----------|----------|-----------|---------|-----------|---------|----------|---------|-----------|---------|-----------|---------|-----------|---------|-----------|---------|-----------|----------|-----------|----------|----------|----------|-----------|----------|-----------|
| 1.1.6.1 | 10 | 1.2.8.3 | 15 | 8.5.6.4 | 11 | 7.2.1.4 | 6 | 7.4.1.1 | 10 | 5.2.1.1 | 17 | 1.2.7.1 | 13 | 8.5.6.1 | 10 | 8.6.1.1 | 11 | 8.4.1.1 | 13 | 5.2.1.1 | 17 | 7.3.2.1 | 14 | 1.1.1.1 | 2 |
| | | 9.11.1.6 | 3 | 9.9.2.2 | 13 | | | 9.9.3.4 | 11 | 9.1.5.1 | 2 | 9.1.1.1 | 6 | 9.1.3.4 | 8 | 9.2.3.4 | 9 | 9.8.1.1 | 7 | 9.1.5.1 | 2 | 9.8.2.2 | 9 | 9.4.3.4 | 11 |
| | | 9.4.2.2 | 7 | | | | | | | | | 9.1.4.2 | 4 | 9.4.4.2 | 5 | | | | | | | | | | |
| | 8 | | 25 | | 24 | | 8 | | 21 | | 19 | | 23 | | 23 | | 20 | | 20 | | 8 | | 23 | | 13 |

Pilot: _____ A/C: _____

L wind/vent →

D

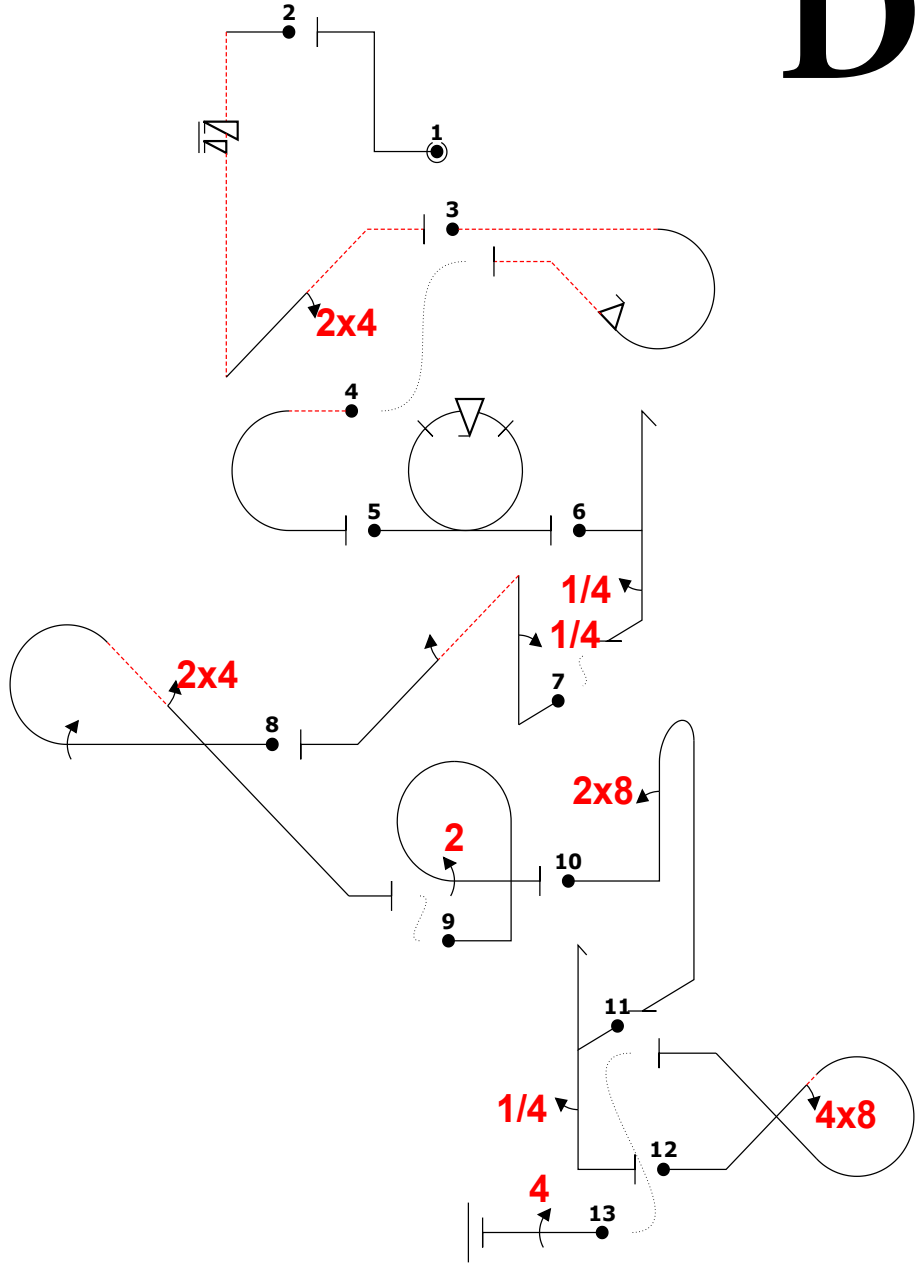

| Fig | Grade | Pos | Remarks |
|-----|-------|-----|---------|
| 1 | . | | |
| 2 | . | | |
| 3 | . | | |
| 4 | . | | |
| 5 | . | | |
| 6 | . | | |
| 7 | . | | |
| 8 | . | | |
| 9 | . | | |
| 10 | . | | |
| 11 | . | | |
| 12 | . | | |
| 13 | . | | |

Positioning **30** .

| | | | |
|---------------|--|----------------|--|
| Too Low | | Trg Violation | |
| Too High | | Wing Rocks | |
| Interruptions | | Disqual Fig | |
| Insertions | | Other(note...) | |

"@L" v "@A" 6s...''ik24'' - "@E" -ic''2f'' - (6,10) "@L" -a "@B" o,f "@F" /h4 (0,2) "@D" 4k2 "@C" 1c.,24...+ (0,3) "@J" rp,22 "@I" ,8b.. "@L" ``h4''> "@G" 48''g (0,12) "@H" 44

| Fig 1 L | K | Fig 2 A | K | Fig 3 E | K | Fig 4 L | K | Fig 5 B | K | Fig 6 F | K | Fig 7 D | K | Fig 8 C | K | Fig 9 J | K | Fig 10 I | K | Fig 11 L | K | Fig 12 G | K | Fig 13 H | K |
|---------|----------|----------|-----------|---------|-----------|---------|----------|---------|-----------|---------|-----------|---------|-----------|---------|-----------|---------|-----------|----------|-----------|----------|----------|----------|-----------|----------|-----------|
| 1.1.6.1 | 10 | 1.2.8.3 | 15 | 8.5.6.4 | 11 | 7.2.1.4 | 6 | 7.4.1.1 | 10 | 5.2.1.1 | 17 | 1.2.7.1 | 13 | 8.5.6.1 | 10 | 8.6.1.1 | 11 | 8.4.1.1 | 13 | 5.2.1.1 | 17 | 7.3.2.1 | 14 | 1.1.1.1 | 2 |
| | | 9.11.1.6 | 3 | 9.9.2.2 | 13 | | | 9.9.3.4 | 11 | 9.1.5.1 | 2 | 9.1.1.1 | 6 | 9.1.3.4 | 8 | 9.2.3.4 | 9 | 9.8.1.1 | 7 | 9.1.5.1 | 2 | 9.8.2.2 | 9 | 9.4.3.4 | 11 |
| | | 9.4.2.2 | 7 | | | | | | | | | 9.1.4.2 | 4 | 9.4.4.2 | 5 | | | | | | | | | | |
| | 8 | | 25 | | 24 | | 8 | | 21 | | 19 | | 23 | | 23 | | 20 | | 20 | | 8 | | 23 | | 13 |

Pilot:

A/C:

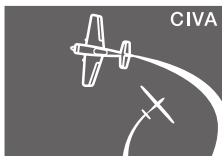

CIVA

FAI

AEROBATICS COMMISSION

E

Form B

Pilot ID

CIVA Intermediate Programme 3

Flight #

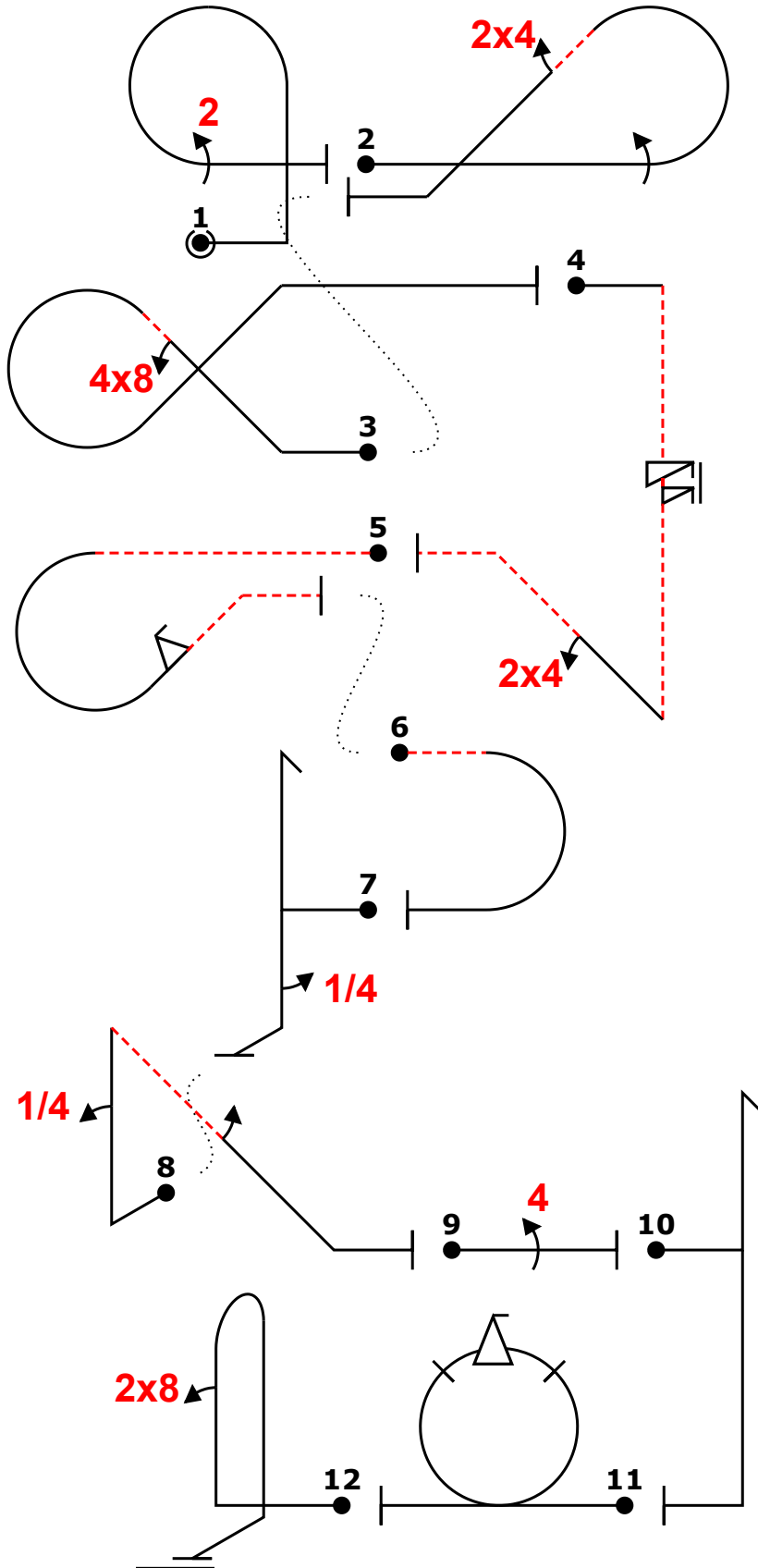
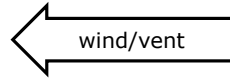

| Power | | | |
|----------------------|----------------------------------|--------------|----|
| Fig | Aresti | K | |
| 1 | 8.6.1.1 J 9.2.3.4 | 11 9 | 20 |
| 2 | 8.5.6.1 C 9.1.3.4 9.4.4.2 | 10 8 5 | 23 |
| 3 | 7.3.2.1 G 9.8.2.2 | 14 9 | 23 |
| 4 | 1.2.8.3 A 9.11.1.6 9.4.2.2 | 15 3 7 | 25 |
| 5 | 8.5.6.4 E 9.9.2.2 | 11 13 | 24 |
| 6 | 7.2.1.4 | 6 | 12 |
| Add. | | | |
| 7 | 5.2.1.1 F 9.1.5.1 | 17 2 | 19 |
| 8 | 1.2.7.1 D 9.1.1.1 9.1.4.2 | 13 6 4 | 23 |
| 9 | 1.1.1.1 H 9.4.3.4 | 2 11 | 13 |
| 10 | 5.2.1.1 | 17 | 12 |
| Add. | | | |
| 11 | 7.4.1.1 B 9.9.3.4 | 10 11 | 21 |
| 12 | 8.4.1.1 I 9.8.1.1 | 13 7 | 20 |
| Total K = 235 | | | |

Pilot
A/C

E

R

wind/vent ←

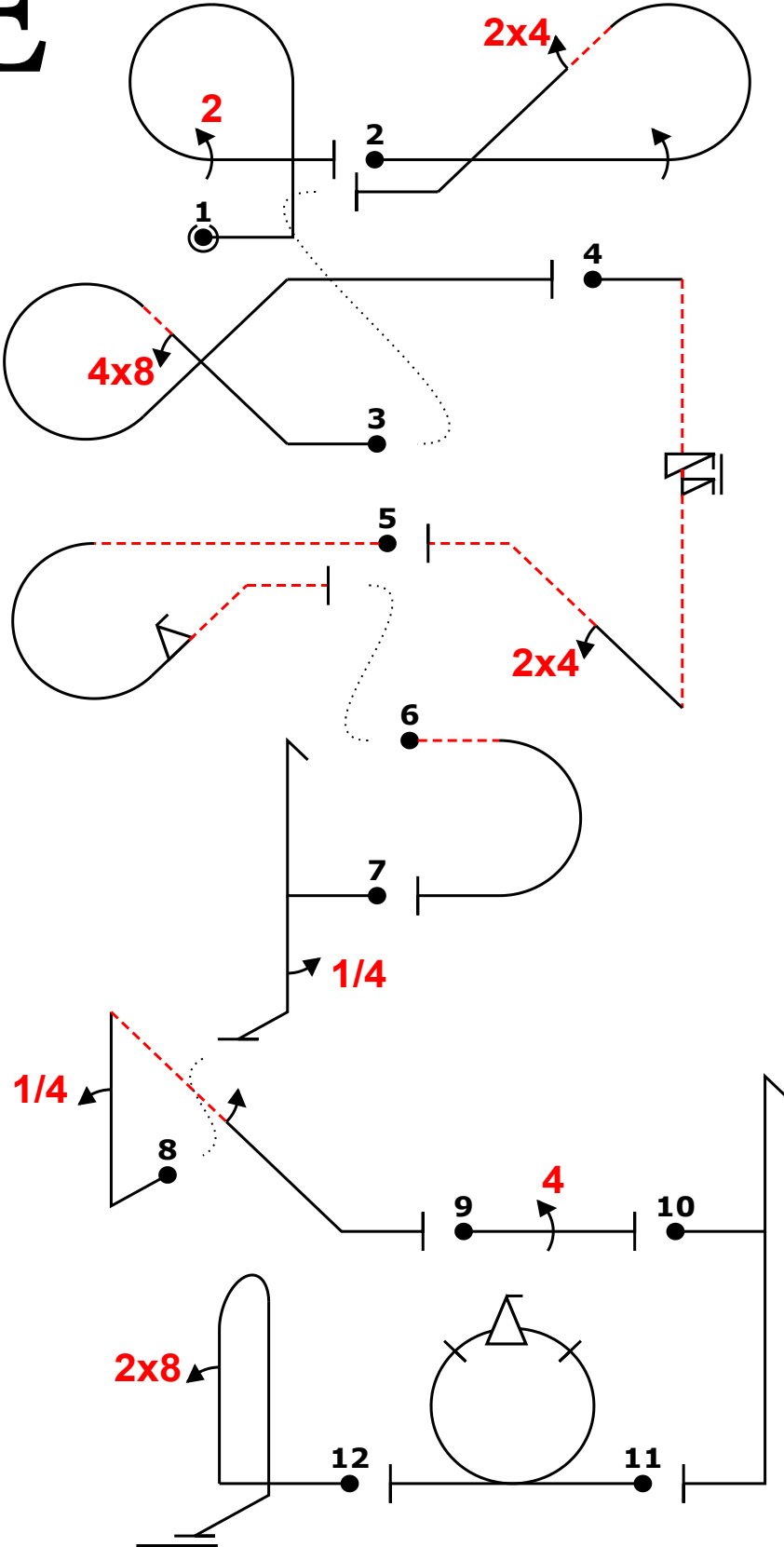

| Fig | Grade | Pos | Remarks |
|-----|-------|-----|---------|
| 1 | . | | |
| 2 | . | | |
| 3 | . | | |
| 4 | . | | |
| 5 | . | | |
| 6 | . | | |
| 7 | . | | |
| 8 | . | | |
| 9 | . | | |
| 10 | . | | |
| 11 | . | | |
| 12 | . | | |

Positioning **30**

| | | | |
|---------------|--|----------------|--|
| Too Low | | Trg Violation | |
| Too High | | Wing Rocks | |
| Interruptions | | Disqual Fig | |
| Insertions | | Other(note...) | |

"@J" rp22 "@C" 1c,24 (5,13) "@G" 48g+++ "@A" .6s..'ik''24'' - "@E" -ic'2f'''''' - (0,8) "@L" -a "@P" h 4 (0,5) "@D" 4k2 "@H" 44 "@L" h..' "@B" of "@I" 8b

| | | | | | | | | | | | | | | | | | | | | | | | |
|---------|----|---------|----|---------|----|---------|----|---------|----|---------|----|---------|----|---------|----|---------|----|----------|----|----------|----|----------|----|
| Fig 1 J | K | Fig 2 C | K | Fig 3 G | K | Fig 4 A | K | Fig 5 E | K | Fig 6 L | K | Fig 7 F | K | Fig 8 D | K | Fig 9 H | K | Fig 10 L | K | Fig 11 B | K | Fig 12 I | K |
| 8.6.1.1 | 11 | 8.5.6.1 | 10 | 7.3.2.1 | 14 | 1.2.8.3 | 15 | 8.5.6.4 | 11 | 7.2.1.4 | 6 | 5.2.1.1 | 17 | 1.2.7.1 | 13 | 1.1.1.1 | 2 | 5.2.1.1 | 17 | 7.4.1.1 | 10 | 8.4.1.1 | 13 |
| 9.2.3.4 | 9 | 9.1.3.4 | 8 | 9.8.2.2 | 9 | 9.1.1.6 | 3 | 9.9.2.2 | 13 | | | 9.1.5.1 | 2 | 9.1.1.1 | 6 | 9.4.3.4 | 11 | | | 9.9.3.4 | 11 | 9.8.1.1 | 7 |
| | 20 | 9.4.4.2 | 5 | | 23 | 9.4.2.2 | 7 | | 24 | | 12 | | 19 | 9.1.4.2 | 4 | | 13 | | 12 | | 21 | | 20 |

Pilot:

A/C:

Team: CZE

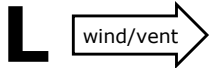

E

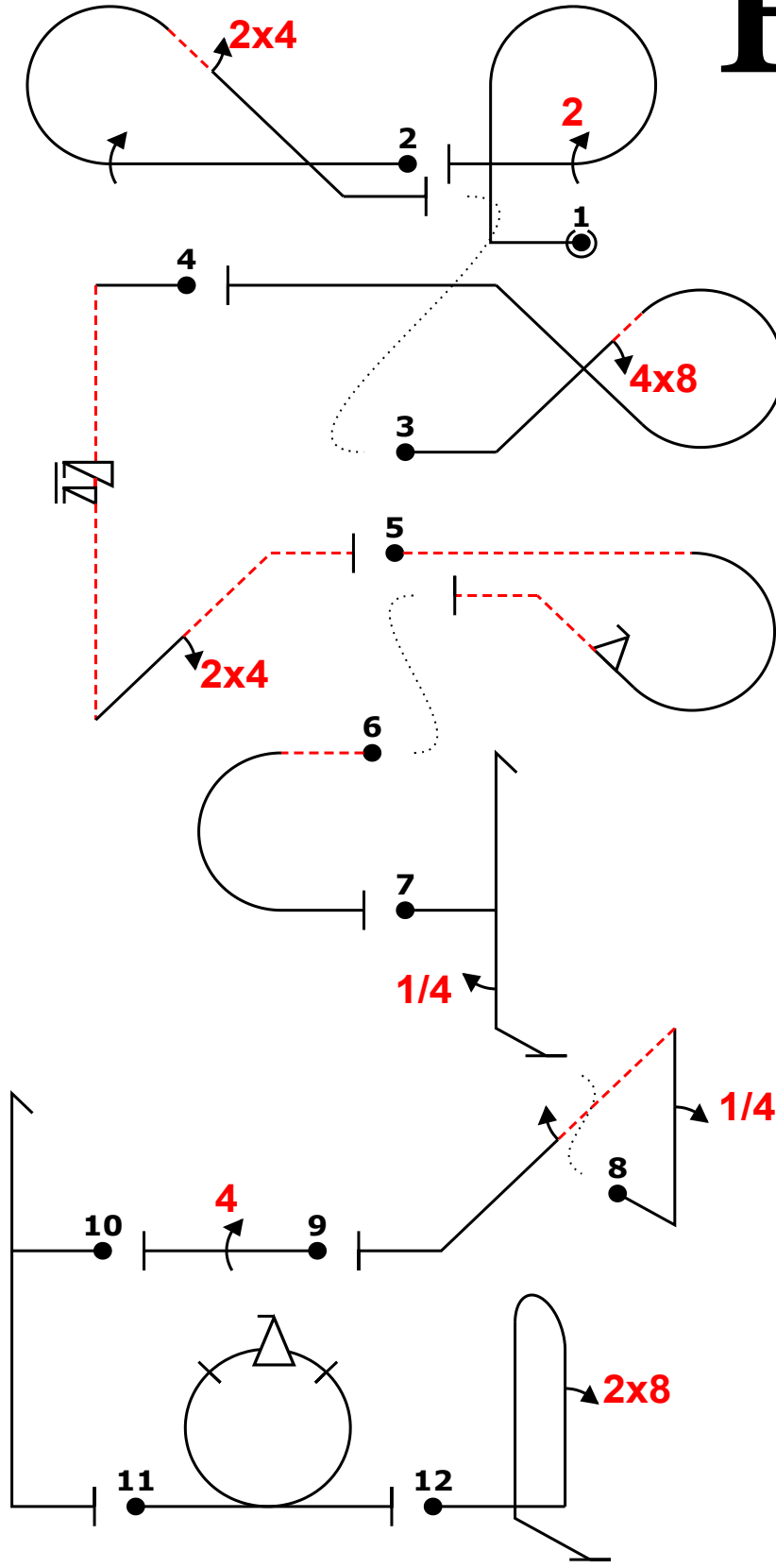

| Fig | Grade | Pos | Remarks |
|-----|-------|-----|---------|
| 1 | . | | |
| 2 | . | | |
| 3 | . | | |
| 4 | . | | |
| 5 | . | | |
| 6 | . | | |
| 7 | . | | |
| 8 | . | | |
| 9 | . | | |
| 10 | . | | |
| 11 | . | | |
| 12 | . | | |

Positioning **30**

| | | | |
|---------------|--|----------------|--|
| Too Low | | Trg Violation | |
| Too High | | Wing Rocks | |
| Interruptions | | Disqual Fig | |
| Insertions | | Other(note...) | |

"@J" rp22 "@C" 1c,24 (5,13) "@G" 48g+++ "@A" .6s..'ik''24''- "@E" -ic'2f''''''- (0,8) "@L" -a "@P" h 4 (0,5) "@D" 4k2 "@H" 44 "@L" h..' "@B" of "@I" 8b

| | | | | | | | | | | | | | | | | | | | | | | | |
|---------|----|---------|----|---------|----|----------|----|---------|----|---------|----|---------|----|---------|----|---------|----|----------|----|----------|----|----------|----|
| Fig 1 J | K | Fig 2 C | K | Fig 3 G | K | Fig 4 A | K | Fig 5 E | K | Fig 6 L | K | Fig 7 F | K | Fig 8 D | K | Fig 9 H | K | Fig 10 L | K | Fig 11 B | K | Fig 12 I | K |
| 8.6.1.1 | 11 | 8.5.6.1 | 10 | 7.3.2.1 | 14 | 1.2.8.3 | 15 | 8.5.6.4 | 11 | 7.2.1.4 | 6 | 5.2.1.1 | 17 | 1.2.7.1 | 13 | 1.1.1.1 | 2 | 5.2.1.1 | 17 | 7.4.1.1 | 10 | 8.4.1.1 | 13 |
| 9.2.3.4 | 9 | 9.1.3.4 | 8 | 9.8.2.2 | 9 | 9.11.1.6 | 3 | 9.9.2.2 | 13 | | | 9.1.5.1 | 2 | 9.1.1.1 | 6 | 9.4.3.4 | 11 | | | 9.9.3.4 | 11 | 9.8.1.1 | 7 |
| | 20 | 9.4.4.2 | 5 | | 23 | 9.4.2.2 | 7 | | 24 | | 12 | | 19 | 9.1.4.2 | 4 | | 13 | | 12 | | 21 | | 20 |

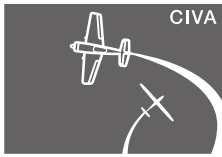

CIVA

FAI

AEROBATICS COMMISSION

WIAC 2019

F

Form B

Pilot ID

CIVA Intermediate Programme 3

Flight #

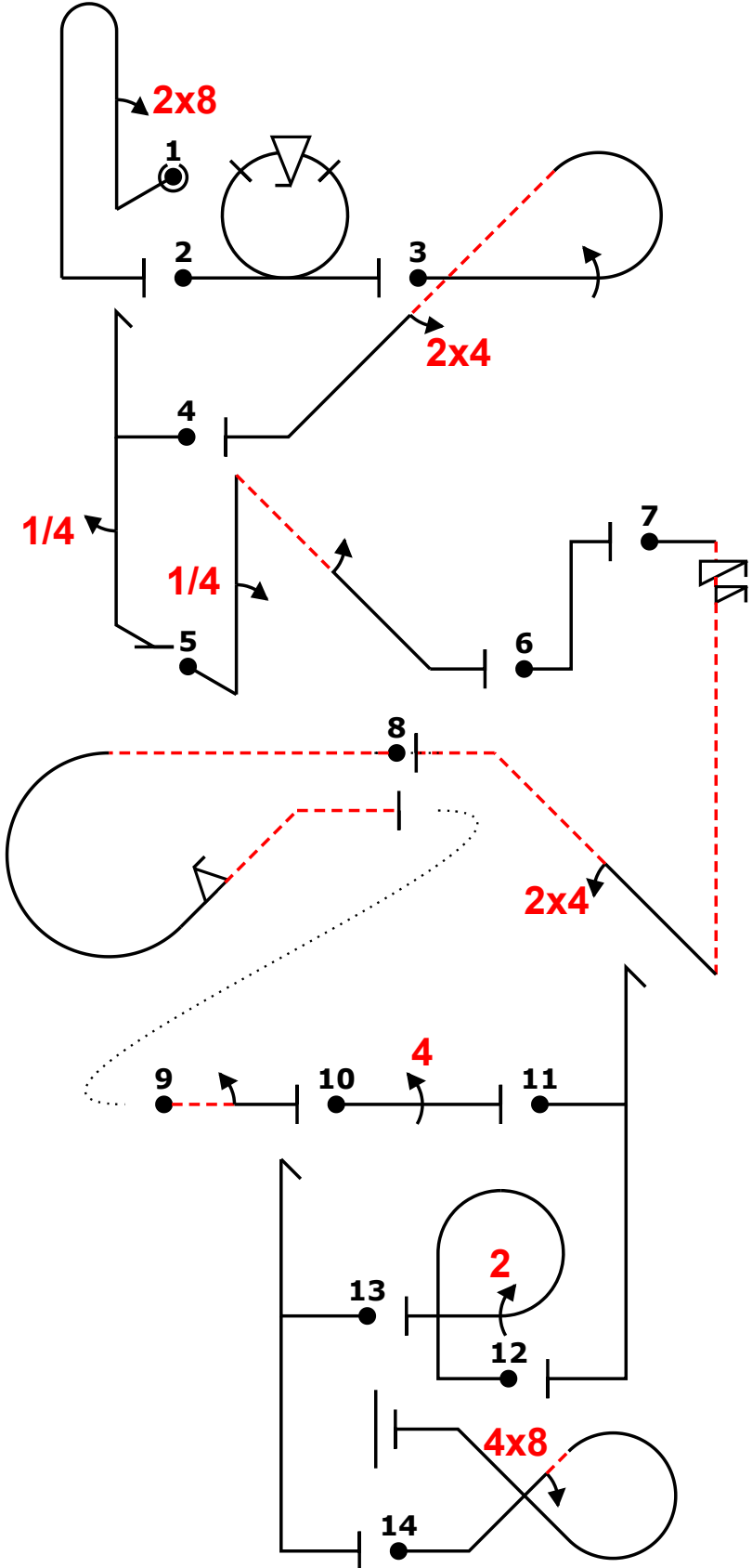
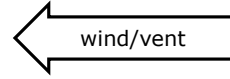

| Power | | | |
|----------------------|----------|----|----|
| Fig | Aresti | K | |
| 1 | 8.4.1.1 | 13 | 20 |
| I | 9.8.1.1 | 7 | |
| 2 | 7.4.1.1 | 10 | 21 |
| B | 9.9.3.4 | 11 | |
| 3 | 8.5.6.1 | 10 | 23 |
| C | 9.1.3.4 | 8 | |
| | 9.4.4.2 | 5 | |
| 4 | 5.2.1.1 | 17 | 19 |
| F | 9.1.5.1 | 2 | |
| 5 | 1.2.7.1 | 13 | 23 |
| D | 9.1.1.1 | 6 | |
| | 9.1.4.2 | 4 | |
| 6 | 1.1.6.1 | 10 | 6 |
| Add. | | | |
| 7 | 1.2.8.3 | 15 | 25 |
| A | 9.11.1.6 | 3 | |
| | 9.4.2.2 | 7 | |
| 8 | 8.5.6.4 | 11 | 24 |
| E | 9.9.2.2 | 13 | |
| 9 | 1.1.1.4 | 2 | 6 |
| Add. | 9.1.3.2 | 4 | |
| 10 | 1.1.1.1 | 2 | 13 |
| H | 9.4.3.4 | 11 | |
| 11 | 5.2.1.1 | 17 | 6 |
| Add. | | | |
| 12 | 8.6.1.1 | 11 | 20 |
| J | 9.2.3.4 | 9 | |
| 13 | 5.2.1.1 | 17 | 6 |
| Add. | | | |
| 14 | 7.3.2.1 | 14 | 23 |
| G | 9.8.2.2 | 9 | |
| Total K = 235 | | | |

ej "@I" -3% '8.b...' "@B" -2% of "@C" -2% '1c...' '24' "F" -2% /h',4.' "@D" -3% ~',|"4.'k''2' "L" -5% v...' "@A" '+'6s.....i k24- (3,0) "@E" 3% -'ic'2f' (-16,15) "@L" -2% -2 "@H" 44 "@L" 'h...' "@J" -2% rp,22 "@L" h.. "@G" -2% ',"|48g

Maciej Kulaszewski Pilot
GenPro HA-XEG A/C

F

← wind/vent **R**

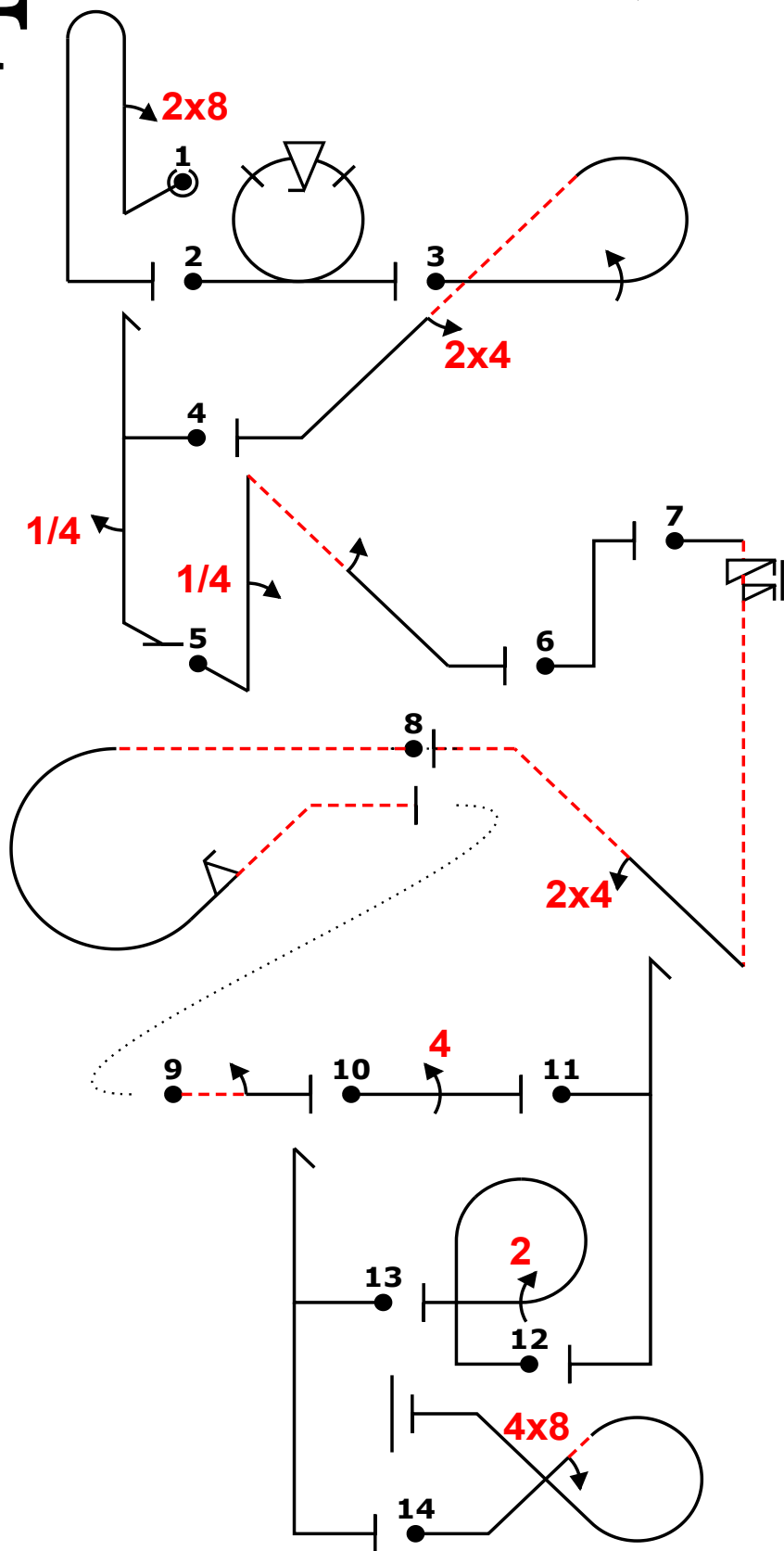

| Fig | Grade | Pos | Remarks |
|-----|-------|-----|---------|
| 1 | . | | |
| 2 | . | | |
| 3 | . | | |
| 4 | . | | |
| 5 | . | | |
| 6 | . | | |
| 7 | . | | |
| 8 | . | | |
| 9 | . | | |
| 10 | . | | |
| 11 | . | | |
| 12 | . | | |
| 13 | . | | |
| 14 | . | | |

Positioning
30 .

| | | | |
|---------------|--|----------------|--|
| Too Low | | Trg Violation | |
| Too High | | Wing Rocks | |
| Interruptions | | Disqual Fig | |
| Insertions | | Other(note...) | |

ej "I" -3% "' ,8.b...'" "@B" -2% of "@C" -2% "1c...24'" "@F" -2% /h' ,4.' "@D" -3% ~' ,|"4.k'2'" "@L" -5 % v...'" "@A" ^+^6s...ik24- (3,0) "@E" 3% -"ic'2F'" - (-16,15) "@L" -2% -2 "@H" 44 "@L" ^h...'" "@J" -2% rp,22 "@L" h...'" "@G" -2% ^,|"48g

| | | | | | | | | | | | | | | | | | | | | | | | | | | | |
|---------|----|---------|----|---------|----|---------|----|---------|----|---------|----|----------|----|---------|----|---------|---|----------|----|----------|----|----------|----|----------|----|----------|----|
| Fig 1 I | K | Fig 2 B | K | Fig 3 C | K | Fig 4 F | K | Fig 5 D | K | Fig 6 L | K | Fig 7 A | K | Fig 8 E | K | Fig 9 L | K | Fig 10 H | K | Fig 11 L | K | Fig 12 J | K | Fig 13 L | K | Fig 14 G | K |
| 8.4.1.1 | 13 | 7.4.1.1 | 10 | 8.5.6.1 | 10 | 5.2.1.1 | 17 | 1.2.7.1 | 13 | 1.1.6.1 | 10 | 1.2.8.3 | 15 | 8.5.6.4 | 11 | 1.1.1.4 | 2 | 1.1.1.1 | 2 | 5.2.1.1 | 17 | 8.6.1.1 | 11 | 5.2.1.1 | 17 | 7.3.2.1 | 14 |
| 9.8.1.1 | 7 | 9.9.3.4 | 11 | 9.1.3.4 | 8 | 9.1.5.1 | 2 | 9.1.1.1 | 6 | | | 9.11.1.6 | 3 | 9.9.2.2 | 13 | 9.1.3.2 | 4 | 9.4.3.4 | 11 | | | 9.2.3.4 | 9 | | | 9.8.2.2 | 9 |
| SF 7 | 20 | SF 4 | 21 | SF 7 | 23 | SF 5 | 19 | SF 7 | 23 | SF 7 | 6 | SF 3 | 25 | SF 4 | 24 | SF 7 | 6 | SF 7 | 13 | SF 5 | 6 | SF 7 | 20 | SF 5 | 6 | SF 7 | 23 |

L
F
 wind/vent →

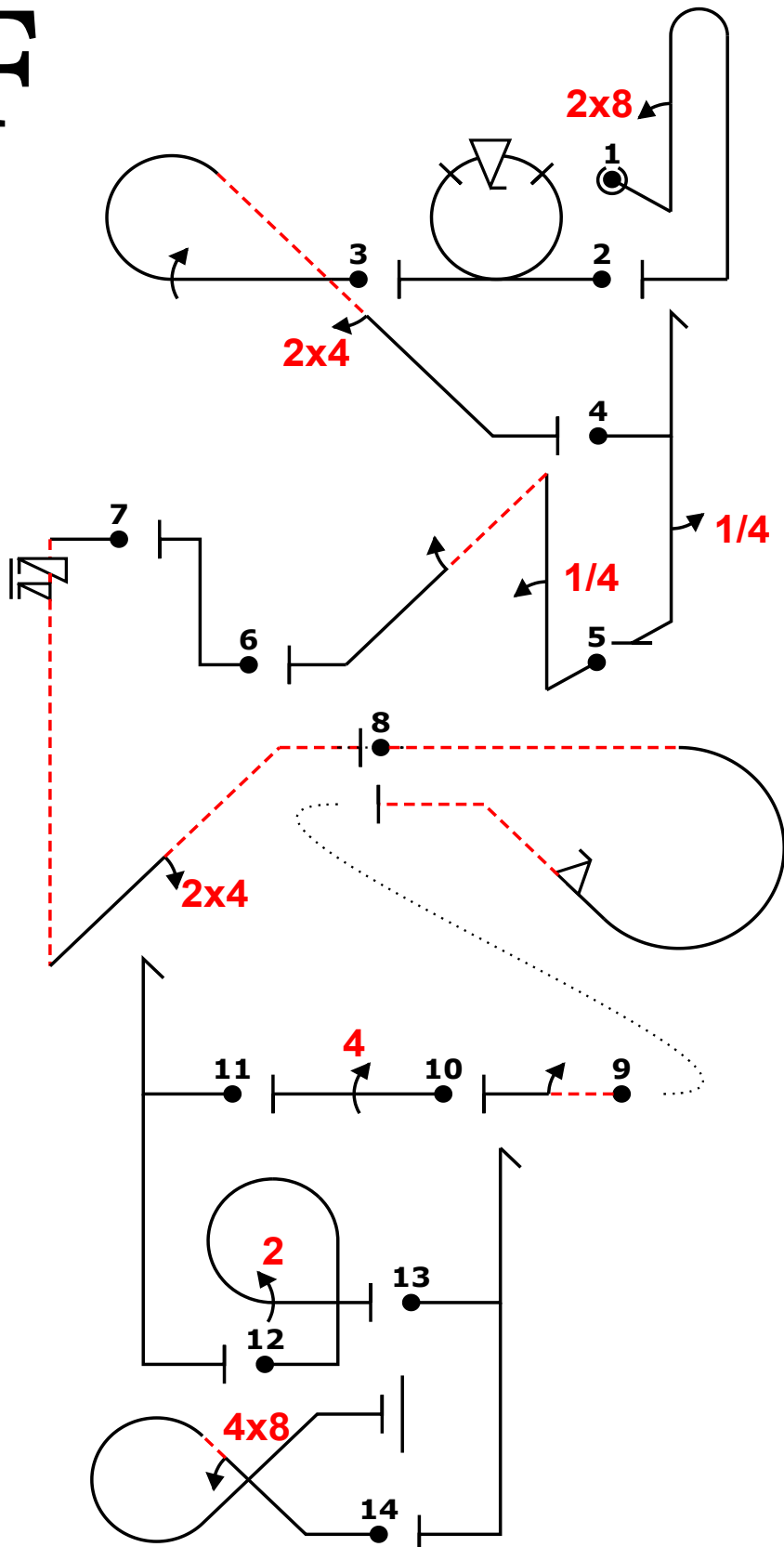

| Fig | Grade | Pos | Remarks |
|-----|-------|-----|---------|
| 1 | . | | |
| 2 | . | | |
| 3 | . | | |
| 4 | . | | |
| 5 | . | | |
| 6 | . | | |
| 7 | . | | |
| 8 | . | | |
| 9 | . | | |
| 10 | . | | |
| 11 | . | | |
| 12 | . | | |
| 13 | . | | |
| 14 | . | | |

Positioning
30

| | | | |
|---------------|--|----------------|--|
| Too Low | | Trg Violation | |
| Too High | | Wing Rocks | |
| Interruptions | | Disqual Fig | |
| Insertions | | Other(note...) | |

ej "I" -3% "' ,8.b... "' "@B" -2% of "@C" -2% "1c... '24' "' "@F" -2% /h' ,4.' "@D" -3% ~' ,|"4.'k' '2' "' "@L" -5 % v... "' "@A" \+ "6s... .ik24- (3,0) "@E" 3% - "ic' 2F' " " (-16,15) "@L" -2% -2 "@H" 44 "@L" 'h... "' "@J" -2% rp,22 "@L" h... "' "@G" -2% " ,|"48g

| Fig 1 I | K | Fig 2 B | K | Fig 3 C | K | Fig 4 F | K | Fig 5 D | K | Fig 6 L | K | Fig 7 A | K | Fig 8 E | K | Fig 9 L | K | Fig 10 H | K | Fig 11 L | K | Fig 12 J | K | Fig 13 L | K | Fig 14 G | K |
|---------|----|---------|----|---------|----|---------|----|---------|----|---------|----|---------|----|---------|----|---------|---|----------|----|----------|----|----------|----|----------|----|----------|----|
| 8.4.1.1 | 13 | 7.4.1.1 | 10 | 8.5.6.1 | 10 | 5.2.1.1 | 17 | 1.2.7.1 | 13 | 1.1.6.1 | 10 | 1.2.8.3 | 15 | 8.5.6.4 | 11 | 1.1.1.4 | 2 | 1.1.1.1 | 2 | 5.2.1.1 | 17 | 8.6.1.1 | 11 | 5.2.1.1 | 17 | 7.3.2.1 | 14 |
| 9.8.1.1 | 7 | 9.9.3.4 | 11 | 9.1.3.4 | 8 | 9.1.5.1 | 2 | 9.1.1.1 | 6 | | | 9.1.1.6 | 3 | 9.9.2.2 | 13 | 9.1.3.2 | 4 | 9.4.3.4 | 11 | | | 9.2.3.4 | 9 | | | 9.8.2.2 | 9 |
| SF 7 | 20 | SF 4 | 21 | SF 7 | 23 | SF 5 | 19 | SF 7 | 23 | SF 7 | 6 | SF 3 | 25 | SF 4 | 24 | SF 7 | 6 | SF 7 | 13 | SF 5 | 6 | SF 7 | 20 | SF 5 | 6 | SF 7 | 23 |



WIAC 2019

G

Form B

Pilot ID

CIVA Intermediate Programme3

Flight #

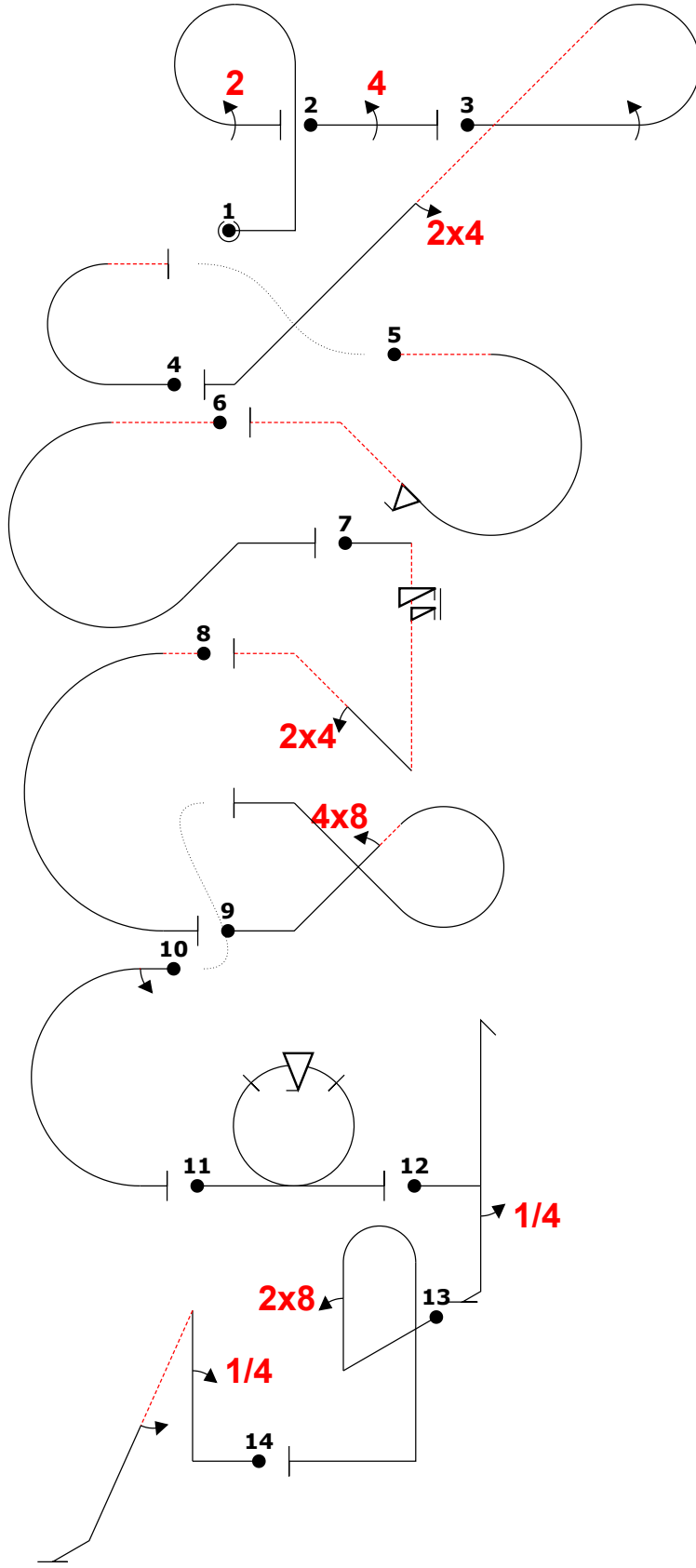
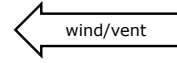

| Power | | | |
|----------------------|----------------------------------|--------------|----|
| Fig | Aresti | K | |
| 1 | 8.6.1.1 J 9.2.3.4 | 11 9 | 20 |
| 2 | 1.1.1.1 H 9.4.3.4 | 2 11 | 13 |
| 3 | 8.5.6.1 C 9.1.3.4 9.4.4.2 | 10 8 5 | 23 |
| 4 | 7.2.1.1 Add. | 6 | 6 |
| 5 | 8.5.6.4 E 9.9.2.2 | 11 13 | 24 |
| 6 | 8.5.5.4 Add. | 10 | 6 |
| 7 | 1.2.8.3 A 9.11.1.6 9.4.2.2 | 15 3 7 | 25 |
| 8 | 7.2.1.4 Add. | 6 | 6 |
| 9 | 7.3.2.1 G 9.8.2.2 | 14 9 | 23 |
| 10 | 7.2.3.3 Add. 9.1.3.2 | 6 4 | 6 |
| 11 | 7.4.1.1 B 9.9.3.4 | 10 11 | 21 |
| 12 | 5.2.1.1 F 9.1.5.1 | 17 2 | 19 |
| 13 | 8.4.1.1 I 9.8.1.1 | 13 7 | 20 |
| 14 | 1.2.7.1 D 9.1.1.1 9.1.4.2 | 13 6 4 | 23 |
| Total K = 235 | | | |

"@J" .rp22+... "@H" 44 "@C" ...ic... '24...' '+' "@L" m- (11,6) "@E" 5% -...ic...2f... "@L" 7% -...ic...+ "@A" ...
6s...ik `24` - "@L" 13% -...a+... "@G" 48g (0,11) "@L" 8% ...2a+... "@B" of "@F" .h`4.+` "@I" 2% ~`8b`~ "@D" ,4k2

Pilot
A/C

G

← wind/vent **R**

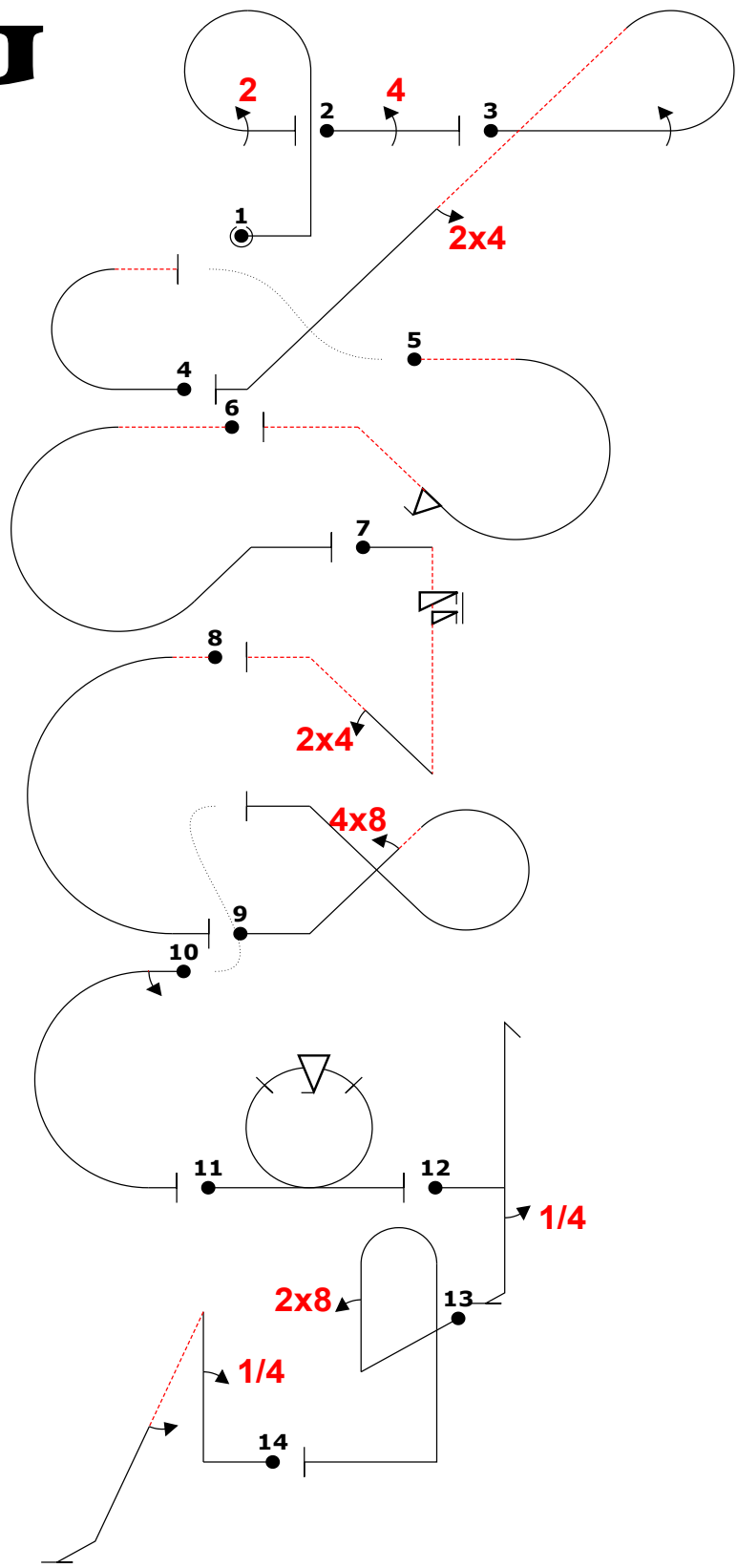

| Fig | Grade | Pos | Remarks |
|-----|-------|-----|---------|
| 1 | . | | |
| 2 | . | | |
| 3 | . | | |
| 4 | . | | |
| 5 | . | | |
| 6 | . | | |
| 7 | . | | |
| 8 | . | | |
| 9 | . | | |
| 10 | . | | |
| 11 | . | | |
| 12 | . | | |
| 13 | . | | |
| 14 | . | | |

Positioning
30 .

| | | | |
|---------------|--|----------------|--|
| Too Low | | Trg Violation | |
| Too High | | Wing Rocks | |
| Interruptions | | Disqual Fig | |
| Insertions | | Other(note...) | |

"@J".rp22+... "@H" 44 "@C" ... "24..." "@L" m- (11,6) "@E" 5% ... "@L" 7% ... "@A" ... "6s..ik" "24" ... "@L" 13% ... "@G" 48g (0,11) "@L" 8% ... "2a+... "@B" of "@F" .h" "4.+... "@I" 2% ... "8b" ~ "@D" ,4k2

| | | | | | | | | | | | | | | | | | | | | | | | | | | | |
|---------|-----------|---------|-----------|---------|-----------|---------|----------|---------|-----------|---------|----------|---------|-----------|---------|----------|---------|-----------|----------|----------|----------|-----------|----------|-----------|----------|-----------|----------|-----------|
| Fig 1 J | K | Fig 2 H | K | Fig 3 C | K | Fig 4 L | K | Fig 5 E | K | Fig 6 L | K | Fig 7 A | K | Fig 8 L | K | Fig 9 G | K | Fig 10 L | K | Fig 11 B | K | Fig 12 F | K | Fig 13 I | K | Fig 14 D | K |
| 8.6.1.1 | 11 | 1.1.1.1 | 2 | 8.5.6.1 | 10 | 7.2.1.1 | 6 | 8.5.6.4 | 11 | 8.5.5.4 | 10 | 1.2.8.3 | 15 | 7.2.1.4 | 6 | 7.3.2.1 | 14 | 7.2.3.3 | 6 | 7.4.1.1 | 10 | 5.2.1.1 | 17 | 8.4.1.1 | 13 | 1.2.7.1 | 13 |
| 9.2.3.4 | 9 | 9.4.3.4 | 11 | 9.1.3.4 | 8 | | | 9.9.2.2 | 13 | | | 9.1.1.6 | 3 | | | 9.8.2.2 | 9 | 9.1.3.2 | 4 | 9.9.3.4 | 11 | 9.1.5.1 | 2 | 9.8.1.1 | 7 | 9.1.1.1 | 6 |
| | | | | 9.4.4.2 | 5 | | | | | | | 9.4.2.2 | 7 | | | | | | | | | | | | | 9.1.4.2 | 4 |
| | 20 | | 13 | | 23 | | 6 | | 24 | | 6 | | 25 | | 6 | | 23 | | 6 | | 21 | | 19 | | 20 | | 23 |

Pilot: _____ A/C: _____



WIAC 2019

H

Form B

Pilot ID

CIVA Intermediate Programme3

Flight #

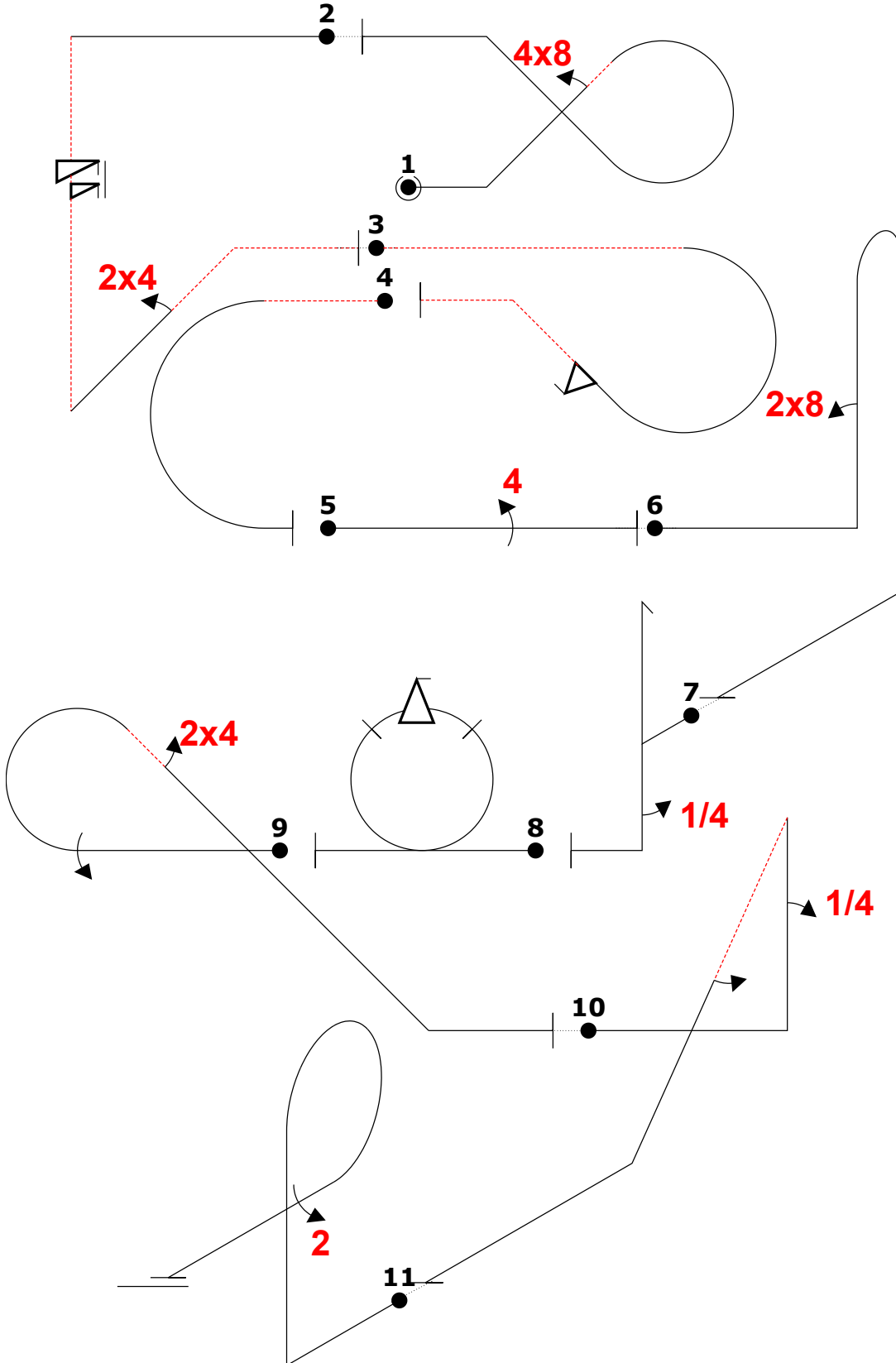
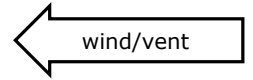

| Power | | | |
|----------------------|----------|----|----|
| Fig | Aresti | K | |
| 1 G | 7.3.2.1 | 14 | 23 |
| | 9.8.2.2 | 9 | |
| 2 A | 1.2.8.3 | 15 | 25 |
| | 9.11.1.6 | 3 | |
| | 9.4.2.2 | 7 | |
| 3 E | 8.5.6.4 | 11 | 24 |
| | 9.9.2.2 | 13 | |
| 4 Add. | 7.2.1.4 | 6 | 24 |
| 5 H | 1.1.1.1 | 2 | 13 |
| | 9.4.3.4 | 11 | |
| 6 I | 8.4.1.1 | 13 | 20 |
| | 9.8.1.1 | 7 | |
| 7 F | 5.2.1.1 | 17 | 19 |
| | 9.1.5.1 | 2 | |
| 8 B | 7.4.1.1 | 10 | 21 |
| | 9.9.3.4 | 11 | |
| 9 C | 8.5.6.1 | 10 | 23 |
| | 9.1.3.4 | 8 | |
| | 9.4.4.2 | 5 | |
| 10 D | 1.2.7.1 | 13 | 23 |
| | 9.1.1.1 | 6 | |
| | 9.1.4.2 | 4 | |
| 11 J | 8.6.1.1 | 11 | 20 |
| | 9.2.3.4 | 9 | |
| Total K = 235 | | | |

"@G" 48g+ (2,0) "@A" ~+++6s...'ik24''-- (-3,0) 3% "@E" -'ic'2f''''-- "@L" 6% -a+'''' "@H" ..44+ (-3,0) "@I" ~+8.'b...++~ (2,-1) "

Pilot
A/C

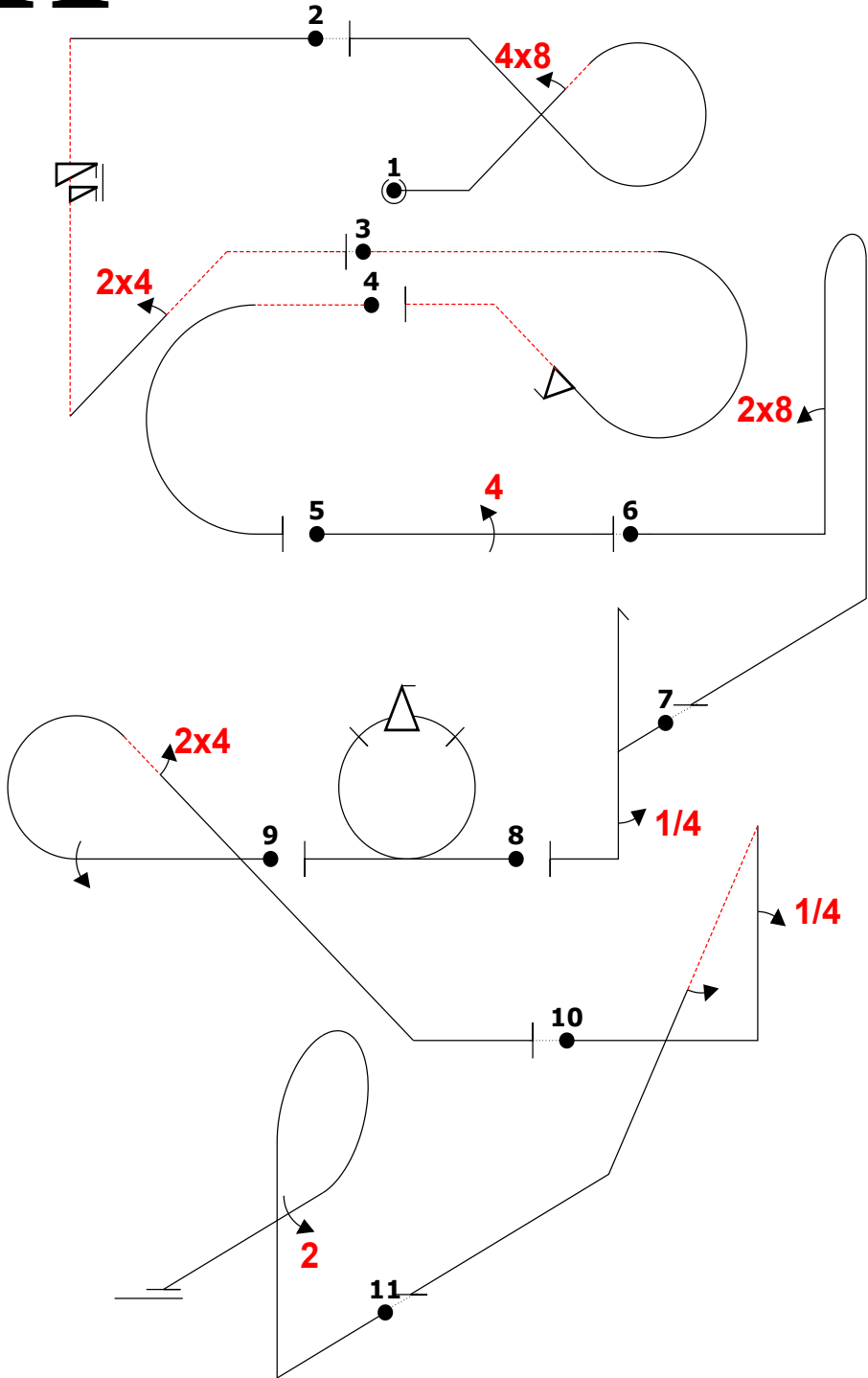

Figure K
235
Total K
265

| | |
|-------------|--------|
| Judges Name | |
| Signature | Number |

| |
|----------|
| Flight # |
|----------|

H



| Fig | Grade | Pos | Remarks |
|-----|-------|-----|---------|
| 1 | . | | |
| 2 | . | | |
| 3 | . | | |
| 4 | . | | |
| 5 | . | | |
| 6 | . | | |
| 7 | . | | |
| 8 | . | | |
| 9 | . | | |
| 10 | . | | |
| 11 | . | | |

Positioning
30 .

| | | | |
|---------------|--|----------------|--|
| Too Low | | Trg Violation | |
| Too High | | Wing Rocks | |
| Interruptions | | Disqual Fig | |
| Insertions | | Other(note...) | |

"@G" 48g+ (2,0) "@A" ~+++'6s...'ik24''-- (-3,0) 3% "@E" -'ic'2f''''-- "@L" 6% -at'''' "@H" ..44+ (-3,0) "@I" ~+++'8.'b...++~ (2,-1) "@F" h4 "@B" of "@c" ''''ic24....+ (-2,0) 2% "@D" ~++',4k2'++++ (2,-1) 1% "@J" ~++.'r p..22+~

| Fig 1 G | K | Fig 2 A | K | Fig 3 E | K | Fig 4 L | K | Fig 5 H | K | Fig 6 I | K | Fig 7 F | K | Fig 8 B | K | Fig 9 C | K | Fig 10 D | K | Fig 11 J | K |
|---------|----|----------|----|---------|----|---------|----|---------|----|---------|----|---------|----|---------|----|---------|----|----------|----|----------|----|
| 7.3.2.1 | 14 | 1.2.8.3 | 15 | 8.5.6.4 | 11 | 7.2.1.4 | 6 | 1.1.1.1 | 2 | 8.4.1.1 | 13 | 5.2.1.1 | 17 | 7.4.1.1 | 10 | 8.5.6.1 | 10 | 1.2.7.1 | 13 | 8.6.1.1 | 11 |
| 9.8.2.2 | 9 | 9.11.1.6 | 3 | 9.9.2.2 | 13 | | | 9.4.3.4 | 11 | 9.8.1.1 | 7 | 9.1.5.1 | 2 | 9.9.3.4 | 11 | 9.1.3.4 | 8 | 9.1.1.1 | 6 | 9.2.3.4 | 9 |
| | 23 | 9.4.2.2 | 7 | | 24 | | 24 | | 13 | | 20 | | 19 | | 21 | 9.4.4.2 | 5 | 9.1.4.2 | 4 | | 23 |
| | | | 25 | | | | | | | | | | | | | | 23 | | | | 20 |

Pilot: _____ A/C: _____

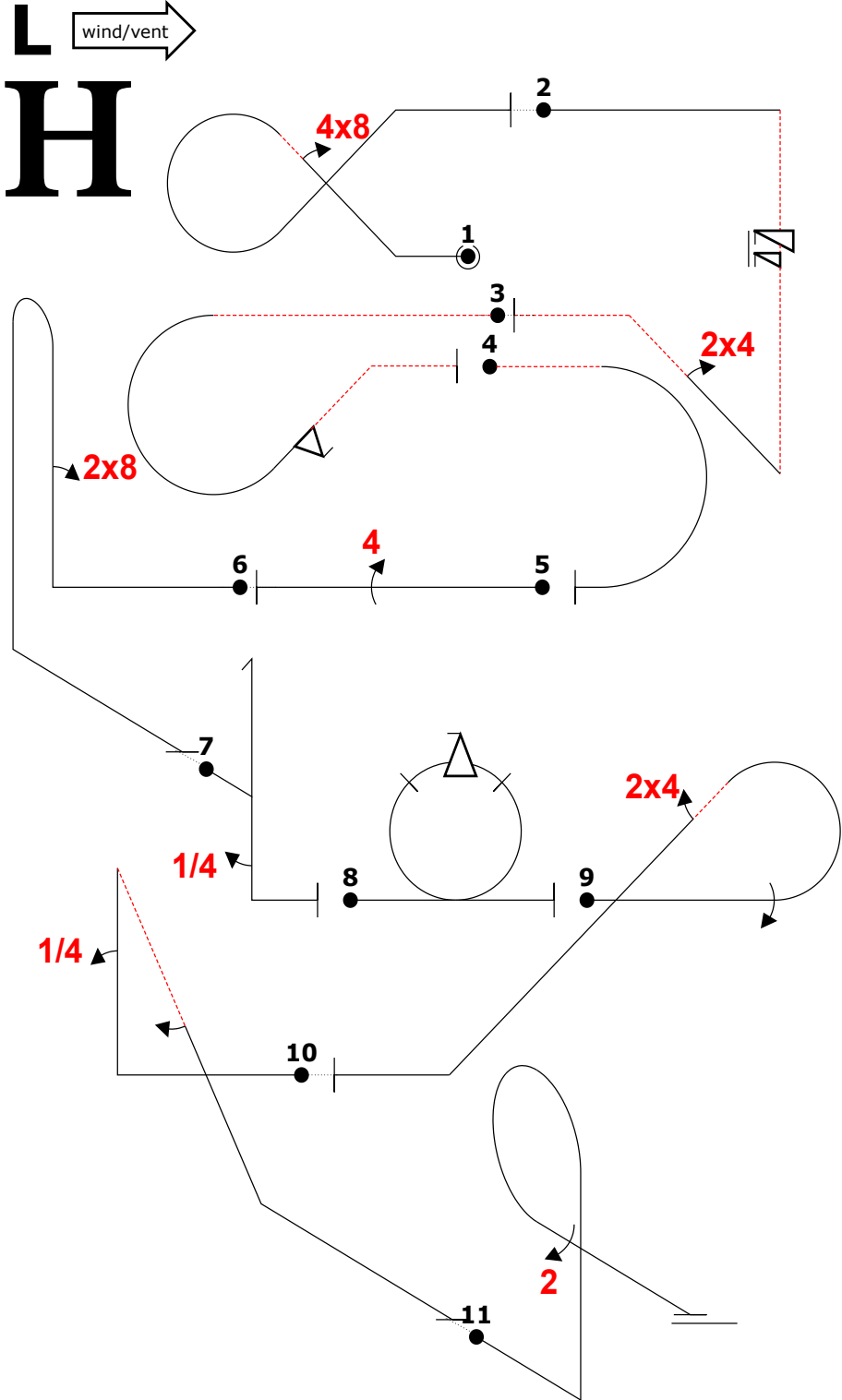

| Fig | Grade | Pos | Remarks |
|-----|-------|-----|---------|
| 1 | . | | |
| 2 | . | | |
| 3 | . | | |
| 4 | . | | |
| 5 | . | | |
| 6 | . | | |
| 7 | . | | |
| 8 | . | | |
| 9 | . | | |
| 10 | . | | |
| 11 | . | | |

Positioning
30 .

| | | | |
|---------------|--|----------------|--|
| Too Low | | Trg Violation | |
| Too High | | Wing Rocks | |
| Interruptions | | Disqual Fig | |
| Insertions | | Other(note...) | |

"@G" 48g+ (2,0) "@A" ~+++'6s..'ik24''-- (-3,0) 3% "@E" -'ic'2f''''- "@L" 6% -a+''' "@H" ..44+ (-3,0) "@I" ~+++'8..'b...+++(2,-1) "@F" h4 "@B" of "@C" ''ic24....+ (-2,0) 2% "@D" ~++',4k2'++++ (2,-1) 1% "@J" ~++..'r p..22+~

| Fig 1 G | K | Fig 2 A | K | Fig 3 E | K | Fig 4 L | K | Fig 5 H | K | Fig 6 I | K | Fig 7 F | K | Fig 8 B | K | Fig 9 C | K | Fig 10 D | K | Fig 11 J | K |
|---------|-----------|----------|----|---------|-----------|---------|-----------|---------|-----------|---------|-----------|---------|-----------|---------|-----------|---------|----|----------|----|----------|-----------|
| 7.3.2.1 | 14 | 1.2.8.3 | 15 | 8.5.6.4 | 11 | 7.2.1.4 | 6 | 1.1.1.1 | 2 | 8.4.1.1 | 13 | 5.2.1.1 | 17 | 7.4.1.1 | 10 | 8.5.6.1 | 10 | 1.2.7.1 | 13 | 8.6.1.1 | 11 |
| 9.8.2.2 | 9 | 9.11.1.6 | 3 | 9.9.2.2 | 13 | | | 9.4.3.4 | 11 | 9.8.1.1 | 7 | 9.1.5.1 | 2 | 9.9.3.4 | 11 | 9.1.3.4 | 8 | 9.1.1.1 | 6 | 9.2.3.4 | 9 |
| | 23 | 9.4.2.2 | 7 | | 24 | | 24 | | 13 | | 20 | | 19 | | 21 | 9.4.4.2 | 5 | 9.1.4.2 | 4 | | 23 |

Pilot: _____ A/C: _____



CIVA Intermediate
Programme3

Figure K
235
Total K
265

Judges Name
Signature Number

Flight #

L wind/vent →

I

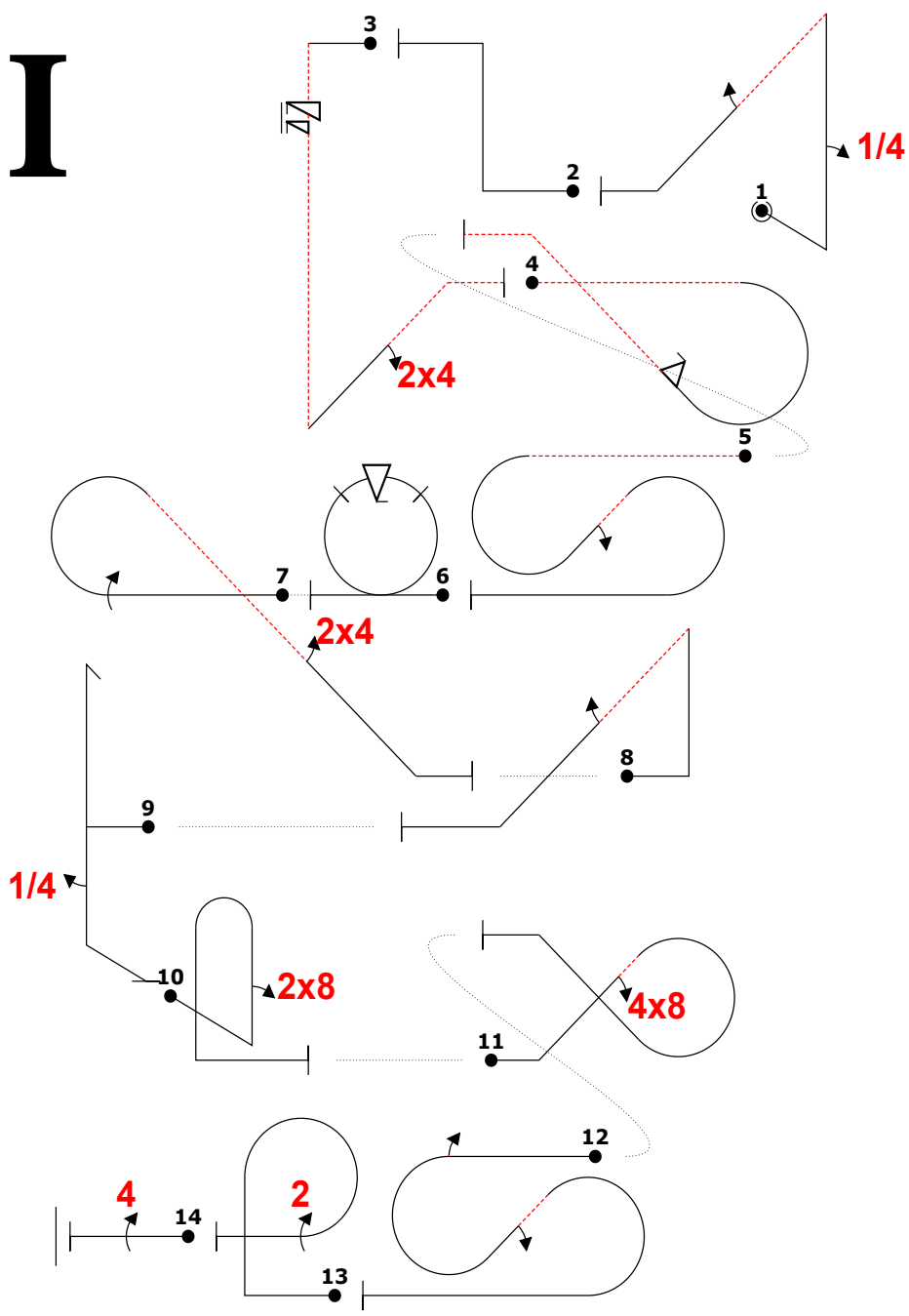

| Fig | Grade | Pos | Remarks |
|-----|-------|-----|---------|
| 1 | . | | |
| 2 | . | | |
| 3 | . | | |
| 4 | . | | |
| 5 | . | | |
| 6 | . | | |
| 7 | . | | |
| 8 | . | | |
| 9 | . | | |
| 10 | . | | |
| 11 | . | | |
| 12 | . | | |
| 13 | . | | |
| 14 | . | | |

Positioning
30 .

| | | | |
|---------------|--|----------------|--|
| Too Low | | Trg Violation | |
| Too High | | Wing Rocks | |
| Interruptions | | Disqual Fig | |
| Insertions | | Other(note...) | |

ej "@0" +4.1'k'2 "@L" ~v'1'~ "@A" ~6s....'ik24'~ "@E" 2% ~'ic'2f'~ (-24,15) "@L" ~'iac(2)~ "@B" ~'~+ f~ (-2,0) "@C" ~'1c....',24'~ (-7,0) "@L" k'2'~+ (14,0) "@F" .h4'~+ "@I" +~'8'~b'~ (-9,0) "@G" ~'+48g (-12,1 5) "@L" ~'~~~~2iac(2) "@J" ~r~p22 "@H" 44

| Fig 1 D | K | Fig 2 L | K | Fig 3 A | K | Fig 4 E | K | Fig 5 L | K | Fig 6 B | K | Fig 7 C | K | Fig 8 L | K | Fig 9 F | K | Fig 10 I | K | Fig 11 G | K | Fig 12 L | K | Fig 13 J | K | Fig 14 H | K |
|---------|----|---------|----|---------|----|---------|----|---------|----|---------|----|---------|----|---------|----|---------|----|----------|----|----------|----|----------|----|----------|----|----------|----|
| 1.2.7.1 | 13 | 1.1.6.1 | 10 | 1.2.8.3 | 15 | 8.5.6.4 | 11 | 7.5.2.4 | 15 | 7.4.1.1 | 10 | 8.5.6.1 | 10 | 1.2.7.1 | 13 | 5.2.1.1 | 17 | 8.4.1.1 | 13 | 7.3.2.1 | 14 | 7.5.5.3 | 15 | 8.6.1.1 | 11 | 1.1.1.1 | 2 |
| 9.1.1.1 | 6 | | | 9.1.1.6 | 3 | 9.2.2 | 13 | 9.1.2.2 | 6 | 9.9.3.4 | 11 | 9.1.3.4 | 8 | 9.1.4.2 | 4 | 9.1.5.1 | 2 | 9.8.1.1 | 7 | 9.8.2.2 | 9 | 9.1.3.2 | 4 | 9.2.3.4 | 9 | 9.4.3.4 | 11 |
| 9.1.4.2 | 4 | | | 9.4.2.2 | 7 | | | | | | | 9.4.4.2 | 5 | | | | | | | | | 9.1.2.2 | 6 | | | | |
| | 23 | | 6 | | 25 | | 24 | | 6 | | 21 | | 23 | | 6 | 19 | | 20 | | 23 | | 6 | | 20 | | 13 | |

Pilot:

A/C:



| | | |
|----------|------------------------------|----------|
| Pilot ID | CIVA Intermediate Programme3 | Form B |
| | | Flight # |

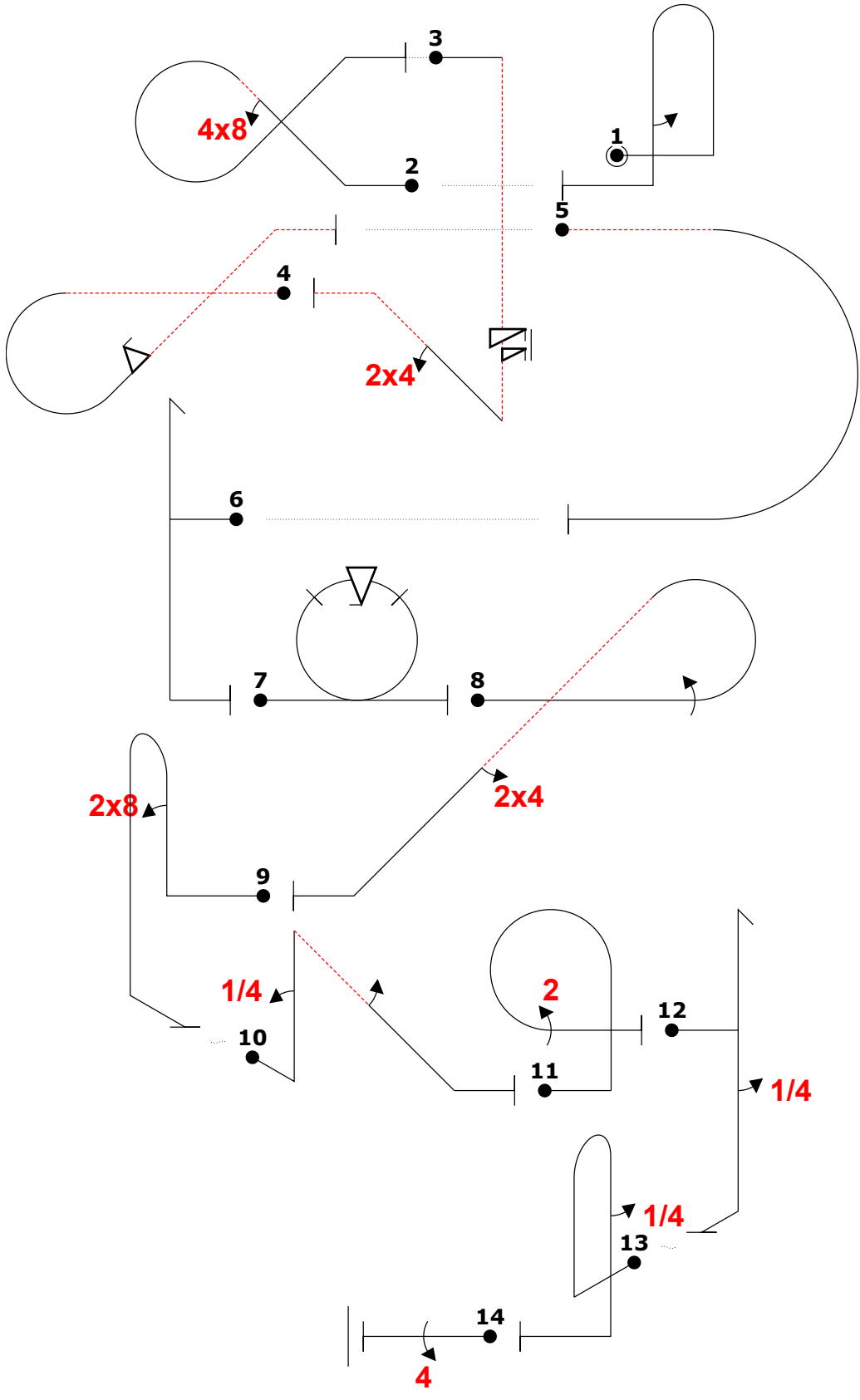
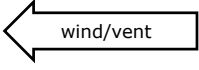

| Power | | | |
|----------------------|----------|----|----|
| Fig | Aresti | K | |
| 1 | 8.4.1.1 | 13 | 6 |
| Add. | 9.1.5.2 | 4 | |
| 2 | 7.3.2.1 | 14 | 23 |
| G | 9.8.2.2 | 9 | |
| 3 | 1.2.8.3 | 15 | 25 |
| A | 9.11.1.6 | 3 | |
| | 9.4.2.2 | 7 | |
| 4 | 8.5.6.4 | 11 | 24 |
| E | 9.9.2.2 | 13 | |
| 5 | 7.2.1.4 | 6 | 6 |
| Add. | | | |
| 6 | 5.2.1.1 | 17 | 6 |
| Add. | | | |
| 7 | 7.4.1.1 | 10 | 21 |
| B | 9.9.3.4 | 11 | |
| 8 | 8.5.6.1 | 10 | 23 |
| C | 9.1.3.4 | 8 | |
| | 9.4.4.2 | 5 | |
| 9 | 8.4.1.1 | 13 | 20 |
| I | 9.8.1.1 | 7 | |
| 10 | 1.2.7.1 | 13 | 23 |
| D | 9.1.1.1 | 6 | |
| | 9.1.4.2 | 4 | |
| 11 | 8.6.1.1 | 11 | 20 |
| J | 9.2.3.4 | 9 | |
| 12 | 5.2.1.1 | 17 | 19 |
| F | 9.1.5.1 | 2 | |
| 13 | 8.4.1.1 | 13 | 6 |
| Add. | 9.1.5.1 | 2 | |
| 14 | 1.1.1.1 | 2 | 13 |
| H | 9.4.3.4 | 11 | |
| Total K = 235 | | | |

"@L" /b2 (-6,0) "@G" 48g (-2,0) "@A"6sik'24''`- "@E" -ic2f.- (11,0) "@L" 14% -a (-18,0) "@L" h.. "@B" of "@C" 1c....'24. "@I" 8b.. (1,0) "@D" 4k'2 "@J" rp22 "@F" /h4.. (-1,0) "@L" b''4..' "@H" 44

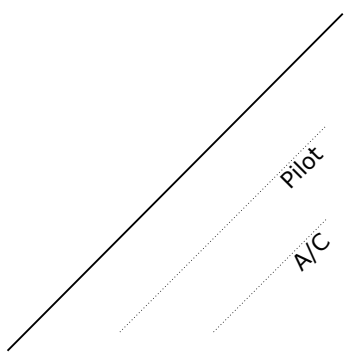

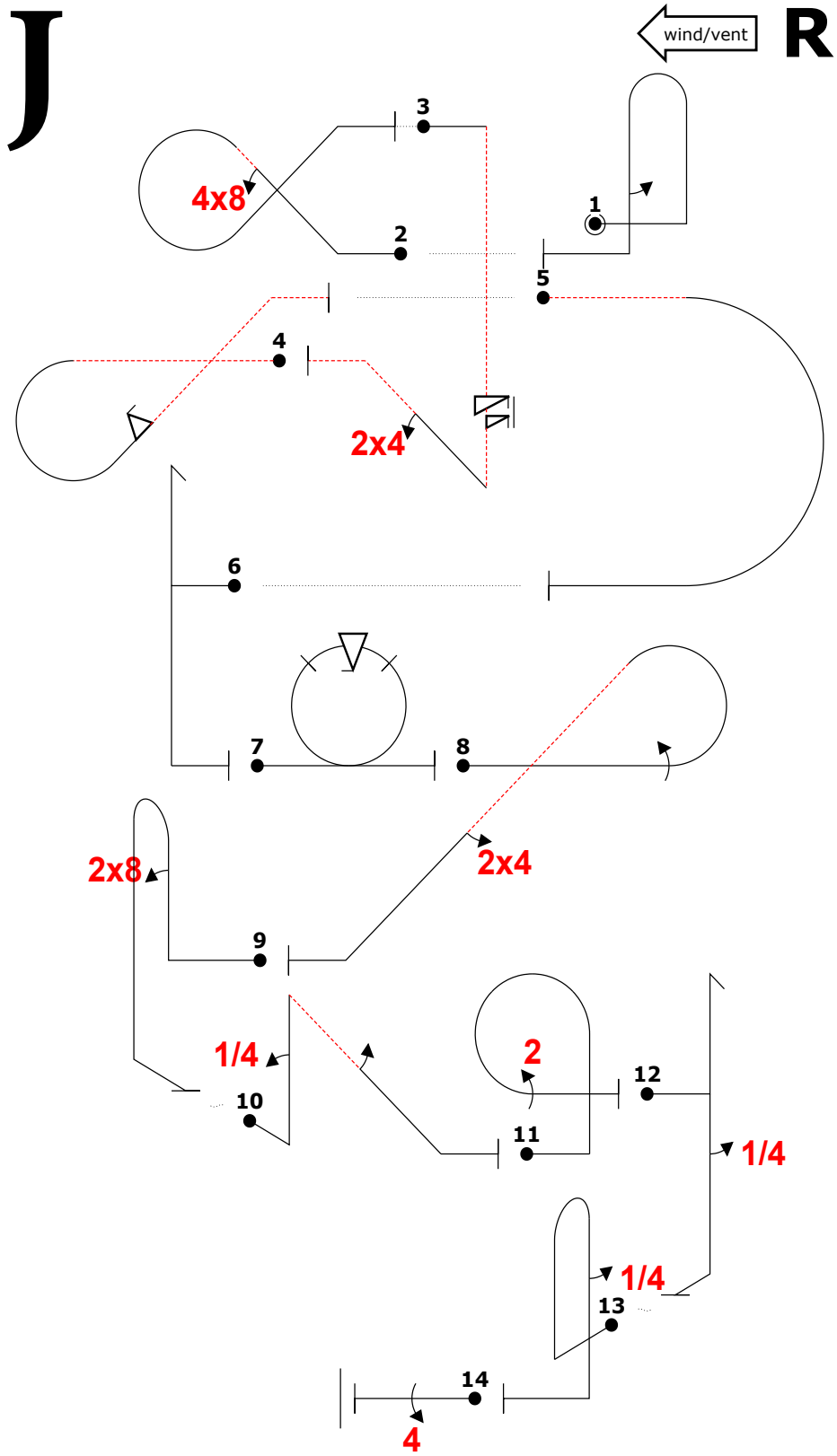

| Fig | Grade | Pos | Remarks |
|-----|-------|-----|---------|
| 1 | . | | |
| 2 | . | | |
| 3 | . | | |
| 4 | . | | |
| 5 | . | | |
| 6 | . | | |
| 7 | . | | |
| 8 | . | | |
| 9 | . | | |
| 10 | . | | |
| 11 | . | | |
| 12 | . | | |
| 13 | . | | |
| 14 | . | | |

Positioning
30

| | | | |
|---------------|--|----------------|--|
| Too Low | | Trg Violation | |
| Too High | | Wing Rocks | |
| Interruptions | | Disqual Fig | |
| Insertions | | Other(note...) | |

"@L" /b2 (-6,0) "@G" 48g (-2,0) "@A"6sik`24`"- "@E" -ic2f.- (11,0) "@L" 14% -a (-18,0) "@L" h.. "@B" of "@C" Ic....`24. "@I" 8b.. (1,0) "@D" 4k`2 "@J" rp22 "@F" /h4.. (-1,0) "@L" b`4. "@H" 44

| Fig 1 L | K | Fig 2 G | K | Fig 3 A | K | Fig 4 E | K | Fig 5 L | K | Fig 6 L | K | Fig 7 B | K | Fig 8 C | K | Fig 9 I | K | Fig 10 D | K | Fig 11 J | K | Fig 12 F | K | Fig 13 L | K | Fig 14 H | K |
|---------|----|---------|----|----------|----|---------|----|---------|---|---------|----|---------|----|---------|----|---------|----|----------|----|----------|----|----------|----|----------|----|----------|----|
| 8.4.1.1 | 13 | 7.3.2.1 | 14 | 1.2.8.3 | 15 | 8.5.6.4 | 11 | 7.2.1.4 | 6 | 5.2.1.1 | 17 | 7.4.1.1 | 10 | 8.5.6.1 | 10 | 8.4.1.1 | 13 | 1.2.7.1 | 13 | 8.6.1.1 | 11 | 5.2.1.1 | 17 | 8.4.1.1 | 13 | 1.1.1.1 | 2 |
| 9.1.5.2 | 4 | 9.8.2.2 | 9 | 9.11.1.6 | 3 | 9.9.2.2 | 13 | | | | | 9.9.3.4 | 11 | 9.1.3.4 | 8 | 9.8.1.1 | 7 | 9.1.1.1 | 6 | 9.2.3.4 | 9 | 9.1.5.1 | 2 | 9.1.5.1 | 2 | 9.4.3.4 | 11 |
| | 6 | | 23 | 9.4.2.2 | 7 | | 24 | | 6 | | 6 | | 21 | 9.4.4.2 | 5 | | 20 | | 23 | | 20 | | 19 | | 6 | 13 | |

Pilot:

A/C:



CIVA Intermediate
Programme3

Figure K
235
Total K
265

Judges Name
Signature Number

Flight #

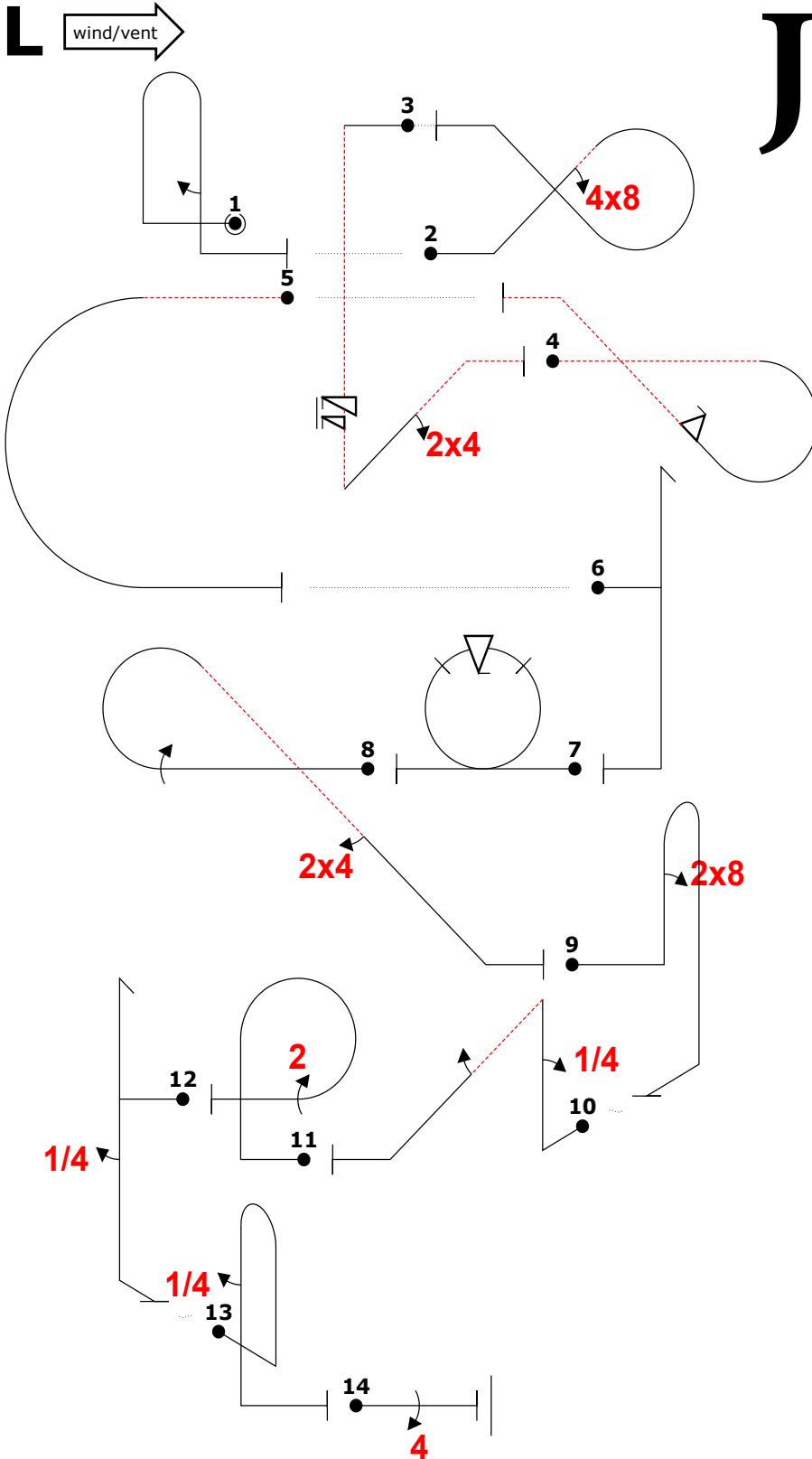

| Fig | Grade | Pos | Remarks |
|-----|-------|-----|---------|
| 1 | . | | |
| 2 | . | | |
| 3 | . | | |
| 4 | . | | |
| 5 | . | | |
| 6 | . | | |
| 7 | . | | |
| 8 | . | | |
| 9 | . | | |
| 10 | . | | |
| 11 | . | | |
| 12 | . | | |
| 13 | . | | |
| 14 | . | | |

Positioning
30 .

| | | | |
|---------------|--|----------------|--|
| Too Low | | Trg Violation | |
| Too High | | Wing Rocks | |
| Interruptions | | Disqual Fig | |
| Insertions | | Other(note...) | |

"@L" /b2 (-6,0) "@G" 48g (-2,0) "@A" ...6sik'24'' - "@E" -ic2f.- (11,0) "@L" 14% -a (-18,0) "@L" h.. "@B" of "@C" ic....'24. "@I" 8b.. (1,0) "@D" 4k'2 "@J" rp22 "@F" /h4.. (-1,0) "@L" b''4.' "@H" 44

| Fig 1 L | K | Fig 2 G | K | Fig 3 A | K | Fig 4 E | K | Fig 5 L | K | Fig 6 L | K | Fig 7 B | K | Fig 8 C | K | Fig 9 I | K | Fig 10 D | K | Fig 11 J | K | Fig 12 F | K | Fig 13 L | K | Fig 14 H | K |
|---------|----|---------|----|----------|----|---------|----|---------|---|---------|----|---------|----|---------|----|---------|----|----------|----|----------|----|----------|----|----------|----|----------|----|
| 8.4.1.1 | 13 | 7.3.2.1 | 14 | 1.2.8.3 | 15 | 8.5.6.4 | 11 | 7.2.1.4 | 6 | 5.2.1.1 | 17 | 7.4.1.1 | 10 | 8.5.6.1 | 10 | 8.4.1.1 | 13 | 1.2.7.1 | 13 | 8.6.1.1 | 11 | 5.2.1.1 | 17 | 8.4.1.1 | 13 | 1.1.1.1 | 2 |
| 9.1.5.2 | 4 | 9.8.2.2 | 9 | 9.11.1.6 | 3 | 9.9.2.2 | 13 | | | | | 9.9.3.4 | 11 | 9.1.3.4 | 8 | 9.8.1.1 | 7 | 9.1.1.1 | 6 | 9.2.3.4 | 9 | 9.1.5.1 | 2 | 9.1.5.1 | 2 | 9.4.3.4 | 11 |
| | 6 | | 23 | 9.4.2.2 | 7 | | 24 | | 6 | | 6 | | 21 | 9.4.4.2 | 5 | | 20 | 9.1.4.2 | 4 | | 20 | | 19 | | 6 | 13 | |

Pilot:

A/C:



K

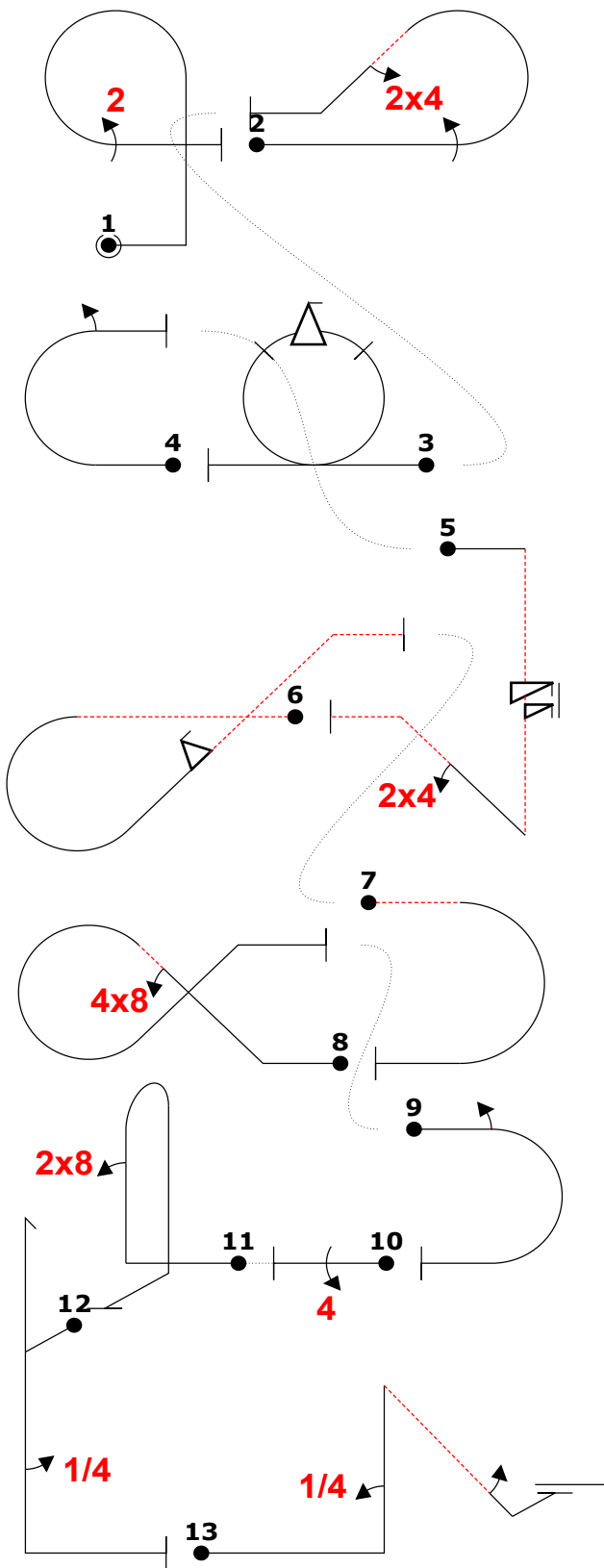

| Fig | Grade | Pos | Remarks |
|-----|-------|-----|---------|
| 1 | . | | |
| 2 | . | | |
| 3 | . | | |
| 4 | . | | |
| 5 | . | | |
| 6 | . | | |
| 7 | . | | |
| 8 | . | | |
| 9 | . | | |
| 10 | . | | |
| 11 | . | | |
| 12 | . | | |
| 13 | . | | |

Positioning
30 .

| | | | |
|---------------|--|----------------|--|
| Too Low | | Trg Violation | |
| Too High | | Wing Rocks | |
| Interruptions | | Disqual Fig | |
| Insertions | | Other(note...) | |

"@J" '1'rp22 "@C" '1'c24' (14,21) "@B" of "@L" m2 (12,13) "@A" '1'6s.ik'24' - "@E" -'1'ic.2f' - (-6,16) "@L" 2% -a "@G" 48g'~ (1,11) "@L" 2a "@H" '44' (2,0) "@I" 8b "@F" h.4.+~ "@O" ++'4'k..2'.....

| Fig 1 J | K | Fig 2 C | K | Fig 3 B | K | Fig 4 L | K | Fig 5 A | K | Fig 6 E | K | Fig 7 L | K | Fig 8 G | K | Fig 9 L | K | Fig 10 H | K | Fig 11 I | K | Fig 12 F | K | Fig 13 D | K |
|---------|----|---------|----|---------|----|---------|---|----------|----|---------|----|---------|---|---------|----|---------|---|----------|----|----------|----|----------|---------|----------|----|
| 8.6.1.1 | 11 | 8.5.6.1 | 10 | 7.4.1.1 | 10 | 7.2.2.1 | 6 | 1.2.8.3 | 15 | 8.5.6.4 | 11 | 7.2.1.4 | 6 | 7.3.2.1 | 14 | 7.2.3.3 | 6 | 1.1.1.1 | 2 | 8.4.1.1 | 13 | 5.2.1.1 | 17 | 1.2.7.1 | 13 |
| 9.2.3.4 | 9 | 9.1.3.4 | 8 | 9.9.3.4 | 11 | 9.1.3.2 | 4 | 9.11.1.6 | 3 | 9.9.2.2 | 13 | | | 9.8.2.2 | 9 | 9.1.3.2 | 4 | 9.4.3.4 | 11 | 9.8.1.1 | 7 | 9.1.5.1 | 2 | 9.1.1.1 | 6 |
| | | 9.4.4.2 | 5 | | | | | 9.4.2.2 | 7 | | | | | | | | | | | | | | 9.1.4.2 | 4 | |
| | 20 | | 23 | | 21 | | 8 | | 25 | | 24 | | 8 | | 23 | | 8 | | 13 | | 20 | | 19 | | 23 |

Pilot:

A/C:



CIVA Intermediate
Programme3

Figure K
235
Total K
265

Judges Name
Signature Number

Flight #

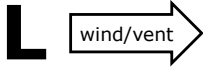

K

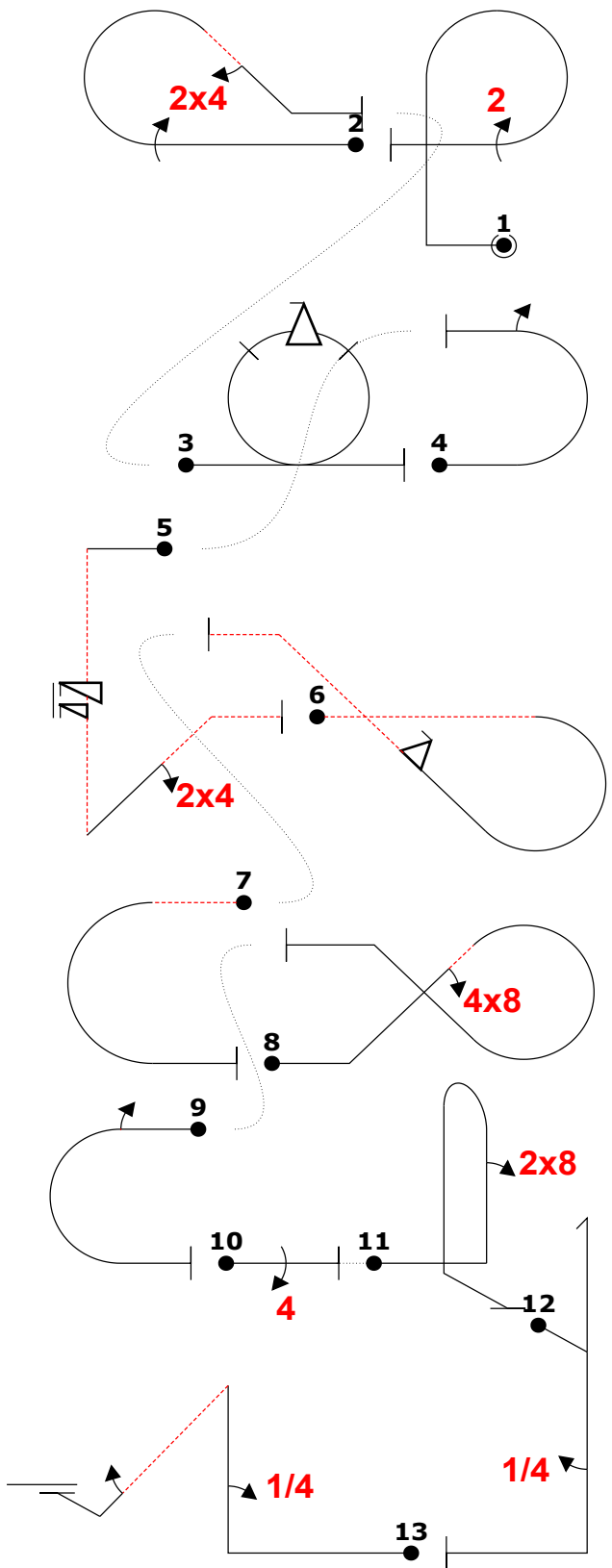

| Fig | Grade | Pos | Remarks |
|-----|-------|-----|---------|
| 1 | . | | |
| 2 | . | | |
| 3 | . | | |
| 4 | . | | |
| 5 | . | | |
| 6 | . | | |
| 7 | . | | |
| 8 | . | | |
| 9 | . | | |
| 10 | . | | |
| 11 | . | | |
| 12 | . | | |
| 13 | . | | |

Positioning
30 .

| | | | |
|---------------|--|----------------|--|
| Too Low | | Trg Violation | |
| Too High | | Wing Rocks | |
| Interruptions | | Disqual Fig | |
| Insertions | | Other(note...) | |

"@J" 'rp22 "@C" 'c24' (14,21) "@B" of "@L" m2 (12,13) "@A" '6s.ik' 24' - "@E" - 'ic.2f' - (-6,16) "@L" 2% -a "@G" 48g' ~ (1,11) "@L" 2a "@H" '44' (2,0) "@I" 8b "@F" h.4.+~ "@O" ++'4'k..2' "

| Fig 1 J | K | Fig 2 C | K | Fig 3 B | K | Fig 4 L | K | Fig 5 A | K | Fig 6 E | K | Fig 7 L | K | Fig 8 G | K | Fig 9 L | K | Fig 10 H | K | Fig 11 I | K | Fig 12 F | K | Fig 13 D | K |
|---------|----|---------|----|---------|----|---------|---|----------|----|---------|----|---------|---|---------|----|---------|---|----------|----|----------|----|----------|---------|----------|----|
| 8.6.1.1 | 11 | 8.5.6.1 | 10 | 7.4.1.1 | 10 | 7.2.2.1 | 6 | 1.2.8.3 | 15 | 8.5.6.4 | 11 | 7.2.1.4 | 6 | 7.3.2.1 | 14 | 7.2.3.3 | 6 | 1.1.1.1 | 2 | 8.4.1.1 | 13 | 5.2.1.1 | 17 | 1.2.7.1 | 13 |
| 9.2.3.4 | 9 | 9.1.3.4 | 8 | 9.9.3.4 | 11 | 9.1.3.2 | 4 | 9.11.1.6 | 3 | 9.9.2.2 | 13 | | | 9.8.2.2 | 9 | 9.1.3.2 | 4 | 9.4.3.4 | 11 | 9.8.1.1 | 7 | 9.1.5.1 | 2 | 9.1.1.1 | 6 |
| | | 9.4.4.2 | 5 | | | | | 9.4.2.2 | 7 | | | | | | | | | | | | | | 9.1.4.2 | 4 | |
| | 20 | | 23 | | 21 | | 8 | | 25 | | 24 | | 8 | | 23 | | 8 | | 13 | | 20 | | 19 | | 23 |

Pilot:

A/C: